

ALLEN&HEATH

iLive



iLive Fixed Format Systems

Getting Started Guide

Publication AP7141

This guide is intended to help the new user quickly learn to configure and operate the fixed format iLive audio mixing system. Fixed format and modular iLive components are fully compatible with each other letting you mix and match any combination of MixRack and Surface according to application and budget.

System operating firmware

The feature set of the iLive system is determined by the firmware (operating software) that runs it. Firmware is updated regularly as new features are added and improvements made, and is available for download from the Allen & Heath web site. This guide relates to **Version 1.9** firmware. Some of the details shown in this guide may differ from those in the current firmware release. Refer to the web site for the latest version and read the Release Notes that come with each version of firmware for further details.

Note: Make sure all your iLive MixRacks, Surfaces and xDR expanders are running the same version of firmware, and that the Editor software, MixPad and Tweak apps are compatible. xDR-16 expanders loaded with V1.9 firmware are not compatible with V1.8 or earlier iLive hardware.

This user guide

This guide provides information on the fixed format iLive system.

Further information

For further information, refer to the user guides associated with each system component.

iDR MixRack Getting Started Guide AP7445 and **xDR-16 Getting Started Guide AP8331** present further information on the iDR-16, iDR-32, iDR-48 and iDR-64 fixed format MixRacks and the xDR-16 Input/Output expander. Use the **HELP MANUAL** available from the iLive Surface TouchScreen **UTILITY** menu and within the **Editor** software. Visit the **Allen & Heath web site** for the latest information on iLive and additional resources for download.



The iLive range of products complies with the European Electromagnetic Compatibility directives 89/336/EEC & 92/31/EEC and the European Low Voltage Directives 73/23/EEC & 93/68/EEC.

Any changes or modifications to the equipment not approved by Allen & Heath could void the compliance of the product and therefore the users authority to operate it.

iLive Fixed Format Systems Getting Started Guide AP7141 Issue 6

Copyright © 2012 Allen & Heath. All rights reserved

ALLEN & HEATH

Allen & Heath Limited, Kernick Industrial Estate, Penryn, Cornwall, TR10 9LU, UK

<http://www.allen-heath.com>

IMPORTANT - Read these instructions before starting:

Safety instructions

Before starting, read the [Important Safety Instructions](#) printed on the sheet supplied with the equipment. For your own safety and that of the operator, technical crew and performers, follow all instructions and heed all warnings printed on the sheet and on the equipment panels.

Software licence agreement

By using this Allen & Heath product and the software within it, you agree to be bound by the terms of the relevant **End User Licence Agreement (EULA)**, a copy of which can be found on the Allen & Heath website in the product's pages. You agree to be bound by the terms of the EULA by installing, copying, or otherwise using the software.



General precautions

- **Damage:** To prevent damage to the controls and cosmetics, avoid placing heavy objects on the control surface, obstructing movement of the motorised faders, scratching the surface or touch screen with sharp objects, or rough handling and vibration.
- **Contamination:** Protect the equipment from damage through liquid or dust contamination. Avoid dust or small objects getting into the fader slots. Cover the mixer when it is not being used for a long period.
- **Cold:** Computer and touch screen technology can be affected by extreme cold. If the equipment has been stored in sub-zero temperatures allow time for it to reach normal operating temperature before use at the venue. Recommended operating temperature range for iLive is 5 to 35 degrees Celsius.
- **Heat:** Avoid using the equipment in extreme heat and direct sunlight. iLive-T and iLive-R Surfaces feature a composite front panel, to which exposure to temperatures above 50°C, with ambient temperature of 35°C, may cause temporary change in appearance. Continued exposure to temperatures above 50°C may cause permanent damage to the composite panel.
- **Ventilation:** Make sure the control surface and rack ventilation slots are not obstructed and that there is adequate air movement around the equipment.
- **Transport:** Use touring grade, purpose designed flight cases with adequate foam lining and internal support for protection.
- **Cleaning:** Do not use chemicals, abrasives or solvents. Clean the control surface with a soft brush and dry lint-free cloth.
- **Servicing:** It is recommended that servicing is carried out only by an authorised Allen & Heath agent. Contact details for your local distributor can be found on the Allen & Heath web site. Allen & Heath do not accept liability for damage caused by maintenance, repair or modification by unauthorised personnel.

Basic system The MixRack (mix engine and most of the I/O) can be positioned on stage, and the Surface (control and local I/O) at the FOH mix position. A single CAT5 cable transports control and local audio between them using the ACE port.



Adding more control Plug into a Network port at the MixRack or Surface to add simultaneous control using one or more laptops running iLive Editor software. Use wired or plug in a router for wireless connection. Add the assignable PL Series devices for distributed control, for example personal monitoring. One or more can be daisy chained from the MixRack PL-Anet port, or distributed via a PL-9 hub. Further control is possible using MIDI, Aviom™ and more.

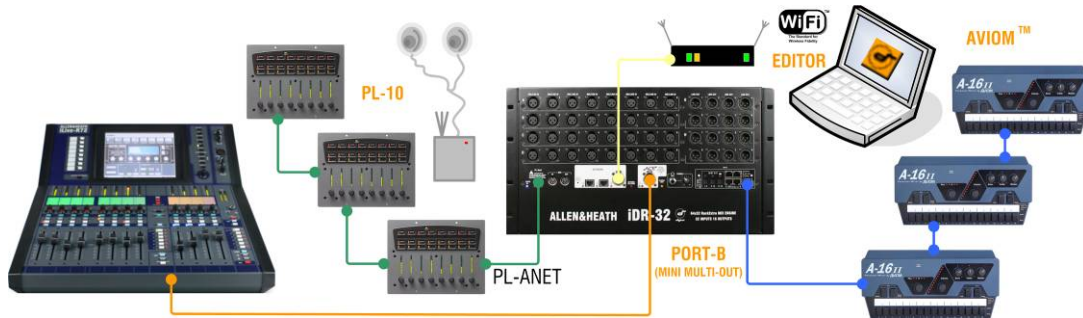

Linked FOH/Monitor system Use the MixRack Port B audio network slot to create a digital split between two systems over a single cable, for example using the ACE or Dante card option. Add a network link if the two systems are to be accessed over the same network using your laptop. The network link can be tunneled via the single cable ACE connection.

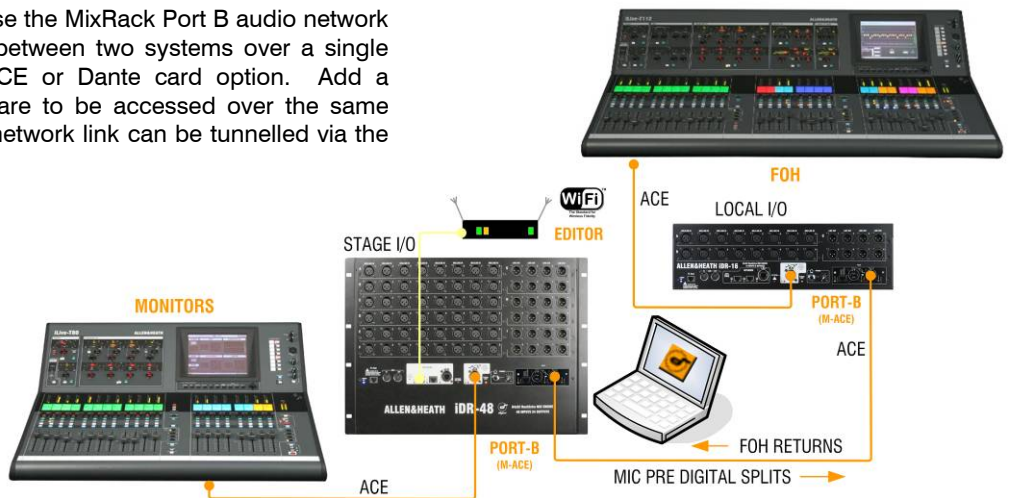

Operating without a Surface Leave your Surface at home and control iLive using just your laptop and iPad for compact or discreet mixing situations. You could add one or more PL Series controllers if you want to assign some physical control, for example important channels, DCAs or master levels.

Linking 2 MixRacks in Dual-Rack mode Expand the number of input channels feeding the 32 mix buses from 64 to 128. Uses the ACE option to link the buses. One Surface can control up to 128 channels.

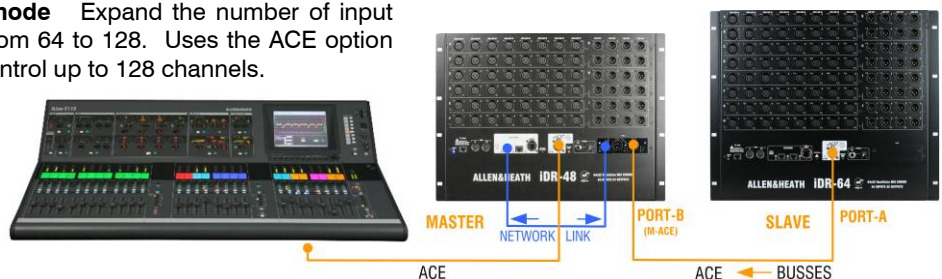

Table of Contents

Introduction	6
System components	7
T Series control layout	8
R Series control layout	9
Step 1 – Connect and power up	10
ACE audio/control link between MixRack and Surface	
Network settings	
Booting the system up and powering down, the Status screen	
Step 2 - Recall a Template Show as a starting point	12
Choose your console application	
Load a Template Show and choose your MixRack and Surface type	
Identify the socket patching and connect the audio	
Step 3 – A few things to know before starting	13
Become familiar with the operating principles	
Set your preferences	
Step 4 – Name and colour channels	15
Using the virtual write-on strip	
Step 5 – Work with the channel processing	16
One button access to the preamp, dynamics, EQ, delay	
Preamp Gain Sharing using Trims	
GEQ and flip to faders	
Step 6 - Work with the mix	18
One button access to the assignments, pre/post settings and levels	
The Routing screen	
Work with the FX, Dynamic EQ, Multiband Compression	
DCAs and mute groups	
Channel Ganging	
COPY / PASTE /RESET	
Step 7 – Patching signals	25
Input, output and insert patching	
Step 8 – Customise your configuration	26
Change the strip layout	
Change the mix bus configuration	
Step 9 - Save your settings	27
The memories – User Profiles, Libraries, Scenes, Shows, Safes, USB Scene Transfer	
Dual-Rack input expansion	31
Linking two racks to expand to 128 input channels	
System Example	32
FOH/Monitor dual system using digital mic split	
iLive-R72 Rack Ears	33
Fitting instructions	
Default Template Show Layout	34
Format, layout and socket patching for 1_FOH-LRSub and 4_MON-8m6st Template Shows	
Specification and Dimensions	36
Manufacturer’s Warranty	39

Introduction

The fixed format iLive is an evolution of the flagship modular iLive digital live mixing range with all the performance and power of its bigger brother in a compact and affordable, easy to use package. It separates the DSP mix engine from the control surface allowing the rack to be positioned on stage and the surface at the FOH (front of house) mix position, linked by a single long distance CAT5 cable carrying control and local FOH audio between them. The fixed format iLive Series comprises 4 sizes of rack and 3 surfaces with non-modular audio I/O giving the user a choice of system according to budget or application. Two MixRacks can be linked in Dual-Rack mode to expand the number of input channels from 64 to 128. One or two xDR-16 expanders can be added for more inputs and outputs and distributed audio. The iLive-R72 Surface can be rack mounted providing all the power of a much bigger system in a compact package. These are also compatible with the modular rack and surface options available within the standard iLive range, perfect for rental companies who may stock both.

Ethernet allows additional or alternative control using wired or wireless laptops running the iLive Editor software. Wireless control is provided with the iPad MixPad (engineer), OneMix (personal monitor) and iPhone Tweak apps. An audio networking slot provides the option to interface with industry standard networks such as Dante or MADI, create a digital mic splitter to link FOH/Monitor systems, connect to digital multitrack recorders, personal monitor systems and more. Further control possibilities include MIDI and the Allen & Heath range of PL Series remote controllers. iLive is fully configurable – the 64x32 mix architecture can be assigned as any combination of mono or stereo groups / auxes / FX / main mix / and matrix, the surface fader strips arranged with any channel or master assigned anywhere to suit your way of mixing, channels and masters named and coloured, physical and network sockets patched, soft keys and PL remote devices assigned... In fact, you can design your own mixer! Settings can be stored in various memory types, and transferred between systems or archived to computer using a USB key.

The iLive is the perfect introduction to digital mixing for new users or operators familiar with analogue consoles. Its analogue style control interface and extensive visual feedback make it quick to learn, reduce operator errors, and allow the fast access most important to live sound mixing.

This guide takes you through the quick first steps in learning to use iLive. A little time spent during a quiet moment pressing buttons and navigating through the various screens should help you become familiar with its more advanced features and capabilities. Refer also to our web site and the other user guides and resources available for the iLive family.

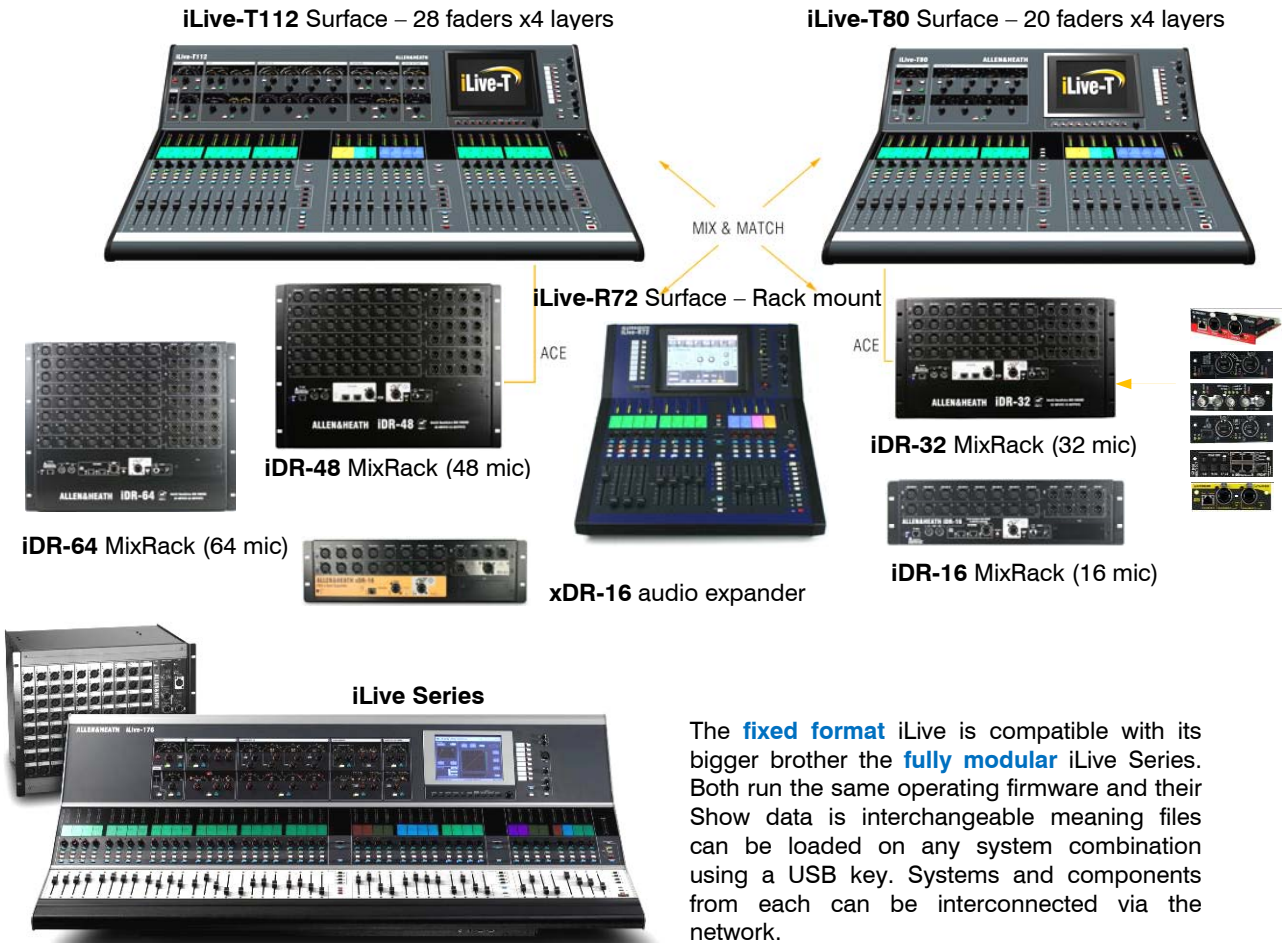

The **fixed format** iLive is compatible with its bigger brother the **fully modular** iLive Series. Both run the same operating firmware and their Show data is interchangeable meaning files can be loaded on any system combination using a USB key. Systems and components from each can be interconnected via the network.

System components



The **MixRack** is the heart of the digital audio processing system, housing the **64x32 DSP mix engine** together with control and audio networking interfaces. The DSP can be configured for mono/stereo and type of mix (group, aux, mains, matrix). The system provides full dynamics, EQ and delay processing for all inputs and masters, 8 built-in 'RackExtra' effects and 16 DCA groups. The 8FX returns add to the 64 channels providing up to 72 sources to the mix. All racks provide the full 64x32 DSP processing and differ only in the number of physical inputs and outputs available. The Port B option allows digital mic splitting and system expansion from a choice of audio networking cards.

IDR-64 Biggest rack: 9U, 64 Mic/Line in, 32 out, Port B

IDR-48 Standard rack: 8U, 48 Mic/Line in, 24 out, Port B

IDR-32 Mid sized rack: 6U, 32 Mic/Line in, 16 out, Port B

IDR-16 Smallest rack: 3U, 16 Mic/Line in, 8 out, Port B

These MixRacks are also available with **AES digital outputs** fitted (last card replaced with 2 dual channel AES sockets).

xDR-16 Audio expander: 16 Mic/Line in, 8 out, Port B



The **Surface** is simply a **network controller** for the MixRack. It has a built-in interface for local audio which is transported to and from the MixRack via the ACE connection along with the Ethernet control. Each bank of faders has 4 or 6 layers providing a total of 72, 80 or 112 control strips depending on Surface size. These strips are freely assignable as inputs, mix masters or DCAs in any combination.



iLive-T112 Biggest surface:
28 faders, 4 layers = 112 strips
16 local line in = 8 TRS, 4 RCA, 2 SPDIF
14 local out = 8 TRS, 2 RCA, 1 SPDIF, Monitor



iLive-T80 Mid sized surface:
20 faders, 4 layers = 80 strips
8 local line in = 4 TRS, 2 RCA, 1 SPDIF
10 local out = 4 TRS, 2 RCA, 1 SPDIF, Monitor

iLive-R72 Smallest surface:
12 faders, 6 layers = 72 strips
8 local line in = 4 TRS, 2 RCA, 1 SPDIF
10 local out = 4 TRS, 2 RCA, 1 SPDIF, Monitor



PL-10



PL-3 PL-4



PL-6



PL-5

PL-9 Hub



PL Series controllers A range of remote controllers is available with assignable switches, LEDs, encoders and faders. A PL-8 4in/4out GPIO controller is also available. These connect to the MixRack via the PL-Anet serial port using CAT5 cable and can be configured using the Surface or laptop. The PL-9 hub is allows star point instead of daisy chain connection. More information on the PL Series is available on the Allen & Heath web site.

T Series Control layout

Channel Processing Strip Analogue style control section with dedicated rotary controls, switches and meters for the channel or mix preamp, HPF, gate, PEQ, compressor and limiter/de-esser. Press the strip **SEL** key to access the processing of the channel or master assigned to it. The controls illuminate when they are available.

TouchScreen For status display, system setup and memory management. To see an alternative graphical view of the processing for the channel or master currently selected make sure none of the keys below the screen is selected.

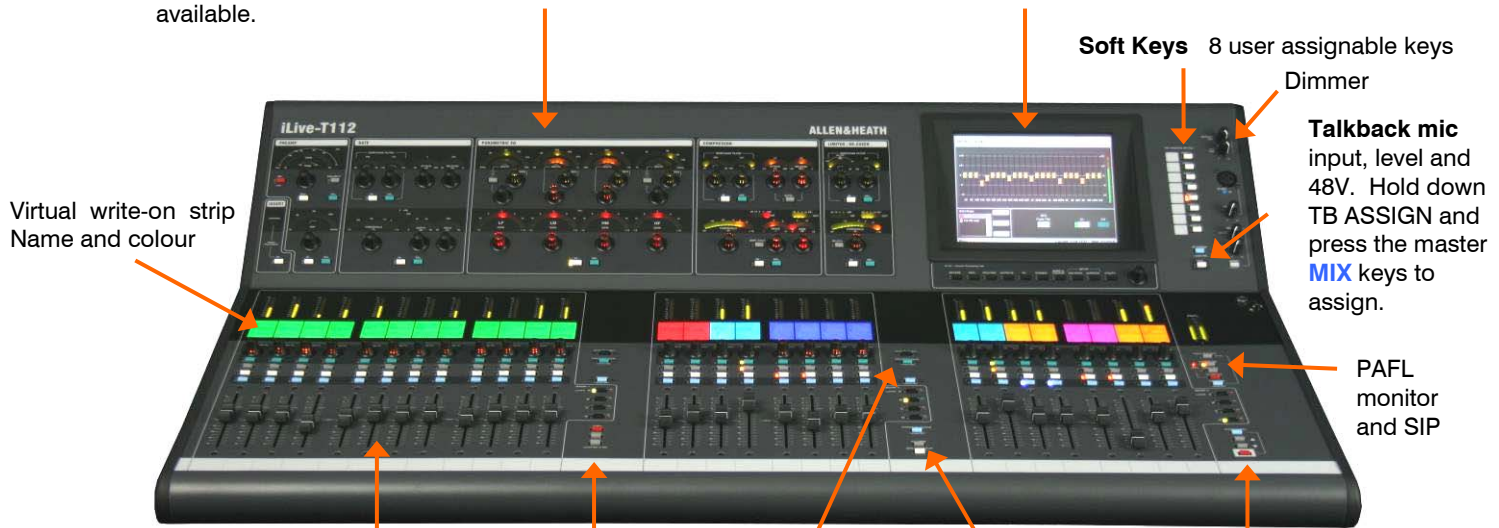

Virtual write-on strip Name and colour

Soft Keys 8 user assignable keys

Dimmer

Talkback mic input, level and 48V. Hold down TB ASSIGN and press the master **MIX** keys to assign.

PAFL monitor and SIP

Copy/Paste/Reset edit keys

Fader Banks Independent groups of fader strips with 4 layers each. Provides control of the Input channel, FX return, Mix master or DCA assigned to it.

SEL opens the channel processing for the selected strip.

MIX presents the sends for the selected strip on faders (or encoders) and assignments and pre/post settings in the strip LCD windows.

ASSIGN and PRE/POST access keys for the selected mix.

While a MIX is active:

Hold down **ASSIGN** and press strip **MIX** keys to toggle the assignments on or off.

Hold down **PRE/POST** and press strip **SEL** keys to toggle pre or post fade.

Hold down **ROTARY SHIFT** to access the second encoder function if it has one.

Hold down **ALT VIEW** to view the channel or socket numbers in place of the name in the LCD windows.

GEQ FADER FLIP to present the GEQ across the faders.

FREEZE IN LAYERS to keep a channel visible across all layers. Hold down and press strip **MIX** keys.

Scene GO recall keys. . These are disabled by default. Use the **SURFACE Preferences** option to enable.

SCENE SAFES to prevent selected channels being overwritten by the memories. Hold down SAFES and press **MIX** keys to toggle on or off.



Lamp sockets

VGA port for external monitor (same view as TouchScreen).

2x USB ports. Plug your USB key in here.

Local PAFL monitor output

Assignable local audio inputs and outputs.

Rows **A, C** = inputs
Rows **B, D** = outputs.

Balanced TRS jack
RCA phono
RCA digital (SPDIF)

Surface to MixRack link
ACE (audio and control over Ethernet) CAT5 cable up to 120m (400 feet)*

* Depends on cable type. Refer to www.allen-heath.com for recommended cable types and maximum lengths.

MIDI in and out

Additional Ethernet ports for connecting laptops and wireless router.

IEC mains power input

iLive-R72 Control layout

Soft Keys 8 user assignable keys

TouchScreen keys When these keys are off the screen displays system status. When these keys are off and a strip **SEL** is active the screen presents the associated channel processing. Use these keys to access system setup and memory management. These override the channel processing view.

Channel Processing Select Press this key to access the processing for the selected channel using the TouchScreen. Controls for the preamp, EQ, dynamics, delay and insert setup are presented. Use the touch controls and screen rotary to adjust the parameters.

Copy/Paste/Reset edit keys
Hold down then press a **SEL** or **MIX** key to copy or reset parameters.

Virtual write-on strip Name, colour and mix status

Fader Banks Two independent groups of fader strips with 6 layers each. Provides control of the Input channel, FX return, Mix master or DCA assigned to it.

SEL opens the channel processing for the selected strip in the TouchScreen.

MIX presents the sends for the selected strip on faders (or encoders) and assignments and pre/post settings in the strip LCD windows.

ASSIGN and PRE/POST access keys for the selected mix.

While a MIX is active:

Hold down **ASSIGN** and press strip **MIX** keys to toggle the assignments on or off. To assign all use the master **MIX** key.

Hold down **PRE/POST** and press strip **SEL** keys to toggle pre or post fade. To assign all use the master **SEL** key.

Hold down **ROTARY SHIFT** to access the second encoder function if it has one.

Dimmer

Talkback Mic Input and level trim. Recessed switch to select 48V phantom power.

Headphones level control

TouchScreen rotary control. Illuminates orange when it is active.

CLEAR ALL PAFL Press once to clear any active Input PAFL. Press again to clear Output PAFL. Input PAFL overrides Output PAFL.

Talkback Hold down TB ASSIGN and press master **MIX** keys to assign.

Scene GO recall keys. These are disabled by default. Use the SURFACE Preferences option to enable.

SCENE SAFES to prevent selected channels being overwritten by the memories. Hold down SAFES and press **MIX** keys to toggle on or off.

Hold down **ALT VIEW** to view the channel or socket numbers instead of name in the LCDs. You can choose to access GAIN using the strip rotaries while the key is pressed.

GEQ FADER FLIP to present the GEQ across the faders.

FREEZE IN LAYERS to keep a channel visible across all layers. Hold down and press strip **MIX** keys.

VGA port for external monitor (same view as TouchScreen).

2x **USB** ports. Plug your USB key in here.

Surface to MixRack link
ACE (audio and control over Ethernet) CAT5 cable up to 120m (400 feet)
*Refer to www.allen-heath.com for recommended cable types and maximum lengths.

Additional Ethernet ports for connecting laptops and wireless router.



Lamp socket

IEC mains power input. Plastic clip to secure power cable.

Local PAFL monitor output

MIDI in and out

System hard reset jumpers

Assignable local audio inputs and outputs.

Row **A** = inputs. Row **B** = outputs.

Balanced TRS jack line level
RCA phono line level
RCA digital (SPDIF)

Step 1 – Connect and power up

The Control Surface



If the system fails to connect:
Check cables,
Go to **Network Connections**
and **Change MixRack**
Read the screen **Help**.

Connect Surface to MixRack

Plug a CAT5 cable up to 120m * (400 feet) between the Surface and MixRack ACE ports.

A 2m cable (part AH7813), 80m drum (part AH7000) or 120m (part AH8721) of suitable cable is available from Allen & Heath.

Note: You only need one connection between the Surface and MixRack. The control network data is transported with the audio via the single cable ACE link. You do not need a second cable for the network link.

Note *: Maximum cable length depends on cable type. Refer to www.allen-heath.com for information on recommended cables.

Network settings

iLive communicates over a TCP/IP network. There are 3 main components – the MixRack, Surface and TouchScreen (built into the surface). These and any other network devices such as a wireless router and laptop need compatible network addresses. Default IP addresses are:

MixRack 192.168.1.1 Sub mask 255.255.255.0
Surface 192.168.1.2
TouchScreen 192.168.1.3

Example compatible settings:

Laptop 192.168.1.10 Sub mask 255.255.255.0
Wireless router 192.168.1.245
Router DHCP range 192.168.1.100 to 192.168.1.200

If the addresses or unit names have been changed and your system fails to connect, or you need to reset the settings, refer to the Troubleshooting page in the TouchScreen HELP.

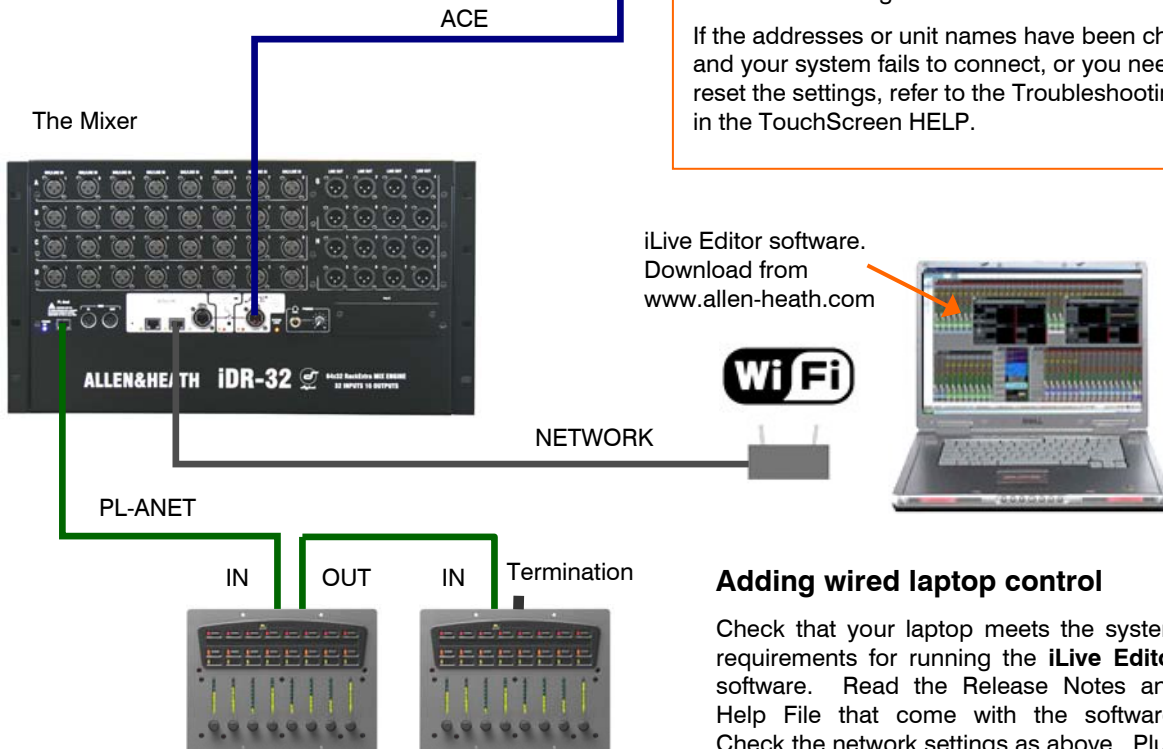

iLive Editor software.
Download from
www.allen-heath.com



Adding wired laptop control

Check that your laptop meets the system requirements for running the **iLive Editor** software. Read the Release Notes and Help File that come with the software. Check the network settings as above. Plug your laptop into any one of the NETWORK ports at the Surface or MixRack. Start the **iLive Editor** program and connect online or offline.

Adding wireless control

With a wireless router plugged into any iLive NETWORK port you can run **Editor** on a wireless laptop, **MixPad** or **OneMix** app on iPads and **Tweak** on an iPhone.

Adding PL Series controllers

Use CAT5 cable to connect the MixRack PL-Anet port to the PL device IN socket. Daisy chain OUT to the next unit, or use a PL-9 hub for star connection. Make sure the termination provided is plugged into OUT of the last device in the chain.

Note: Once connected, the PL controls need to be configured. Settings can be saved as library items.



Secure the mains cable in the clip provided here.

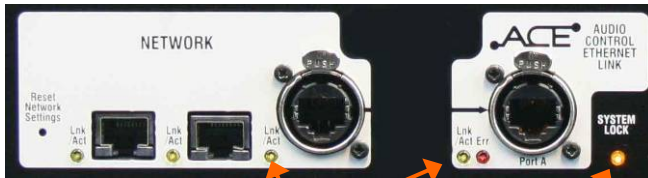

The yellow Lnk/Act LEDs for connected sockets flash at a steady rate once the link is established.

If one or more pulse at a slow rate or the red **Err** LED remains lit then check that the cables are correctly plugged in and are not faulty.

At the MixRack: Indicates that the audio is sync locked to the selected clock source.

At the Surface: Indicates that the surface audio is sync locked to the MixRack.

Switch power on

Switch on the MixRack first, then the Surface by pressing their rear panel power ON switches.

The system remembers the settings on power down. These are restored next time you switch the system on.

Boot up time

MixRack It takes around 15 seconds for the DSP to start passing audio with the same settings current at last power down. You should hear the relays click as they connect the outputs once the MixRack has booted.

Surface In just over 1 minute the strip LCD displays turn on and the Surface is ready to take control of the mix.

TouchScreen It takes a little longer for the TouchScreen to complete its boot up process. In around 2 minutes the screen is ready and the system fully booted.

Status indicators

Once booted, check that the blue POWER ON indicators are lit and the various system status LEDs indicating correctly.

The STATUS screen

With all the TouchScreen keys turned off and no channel selected the screen displays status information about the system. A **red cross** displays in place of the **green tick** if a problem is detected. A **yellow triangle** also displays in the lower toolbar if an error is detected and logged. The yellow triangle should clear after viewing the **Event Log** in the **UTILITY / Diagnostics** screen.

Displays the current firmware version loaded. A red cross warns if a software error has been detected.

Indicates that the MixRack is sync locked to the selected audio clock source.

A green tick indicates that the temperature sensed within the rack and surface is within normal operating range.

Real time clock. You can change the time using the **UTILITY / Configuration** screen.



Information about the ACE Surface to MixRack audio/control connection. **Status** displays error detection over the previous minute in time, green = none, yellow = few, red = many errors. **Net Bridge** indicates correct operation of the Ethernet link over ACE. **Surface Lock** indicates that the Surface audio is sync locked to the MixRack.

If an optional audio network card is fitted to the MixRack Port B slot then its status is displayed here.

Warns that the MixRack Boot Scene option is set. This will recall starting point settings for the MixRack each time it is powered up or restarted. This feature is popular in installed systems using remote control panels rather than a surface.

Step 2 – Recall a ‘Template Show’ as a starting point

The iLive has a fully configurable audio architecture and control layout and socket patching letting you customise the way you work. It would be a daunting task for the new user if we gave them a ‘blank canvas’ to start from scratch. Instead we have provided a set of ‘Template’ Show memories which give you a choice of classic console format to load in as a quick starting point. These emulate the familiar architecture and logical layout of well equipped analogue consoles. Once you are comfortable working with iLive you can make changes to your set up and save these as your own ‘User’ Shows.

A default show is already loaded when the iLive is shipped from the factory. This is 1_FOH-LRSub. Details of the layout and patching of this and the 4_MON-8m6st show are presented at the rear of this guide.

1_FOH-LRSub Stereo with Pan and separate Sub level accessible on each channel using the shifted rotary function.

2_FOH-LR Standard stereo main mix with LR master faders and channel Pan.

3_FOH-LCR Conventional LCR panning - left through centre to right.

4_MON-8m6st Dedicated monitor mixer with 8 mono+6 stereo mixes plus Wedge/IEM monitor.

5_Split_FOH-slave FOH mixer receiving its inputs from the monitor console via the Port B digital audio network.

6_Split_MON-slave Monitor mixer receiving its inputs from the FOH console via the Port B digital audio network.

7_DualRack-FOH One Surface controlling two MixRacks combined to provide up to 128 channels.

Note: Recalling a Show overwrites all the system settings including the DSP mix architecture, Surface configuration, current parameters, all the Scene and Library memories. Archive your current settings as a **User Show** before recalling the Template Show if you want to keep these to use again in the future.

Template Shows available:

FOH These make a good starting point for general purpose live mixing whether dedicated FOH or a single console mixing monitors from FOH. They provide a classic Group/Aux/Mains/Matrix bus architecture and differ only in the type of Main mix configured. Other Main mix types can be configured from within these Template Shows.

MON This recalls a format and layout suitable for dedicated monitor mixing, with a combination of mono and stereo auxes and engineer’s dual Wedge/IEM monitor.

Split Use these when the system gets its inputs from a ‘master’ console via a digital mic split such as Ace, Dante, MADI or EtherSound.

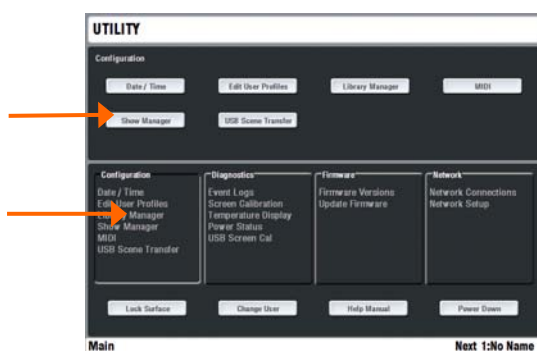

Load a Template Show

Press the UTILITY key below the TouchScreen - **UTILITY / Configuration / Show Manager**. Highlight the **Templates** item. Touch the + button to expand the tree. Select a show from the list and touch **Recall**. A show can take several minutes to load depending on the amount of data stored.



Recall settings for your iLive system

When the recall has finished, a 'Go to SCENE page' message is displayed on the strips. This is to remind you to load two Scenes, one to match your iLive MixRack and the other your Surface. These recall the strip layout for your Surface and configure the output patching for your MixRack. Press the **SCENES** key below the TouchScreen. **Recall** the two Scenes.

Customise and save your settings

You may wish to make changes to the configuration and save the new settings as a **User Show**. Before you do this we suggest you **Clear** the contents of Scene 1 - 16 ready for your own application.

Step 3 – A few things to know before starting

Before working with the iLive familiarise yourself with its control layout and operating principles.

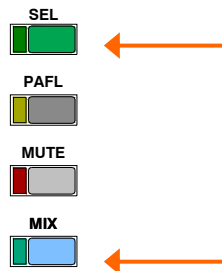

Two important keys

SEL - Select the channel processing. View and adjust the parameters for that channel. Within the processing section use these keys to open individual processing blocks on the screen, or press and hold to send the signal at that point to the PAFL system. These keys are also used when copying or resetting processing parameters, and for setting up ganging, name & colour and strip layout.

MIX - Select the mix you want to work with. View and adjust the assignments, pre/post settings, levels and pan. There is an option to choose to use either fader or rotary sends for each Aux or Matrix mix. These keys are also used when assigning and copying mix parameters, and setting talkback assignments, channel safes and more.

Fader Strip LCD display

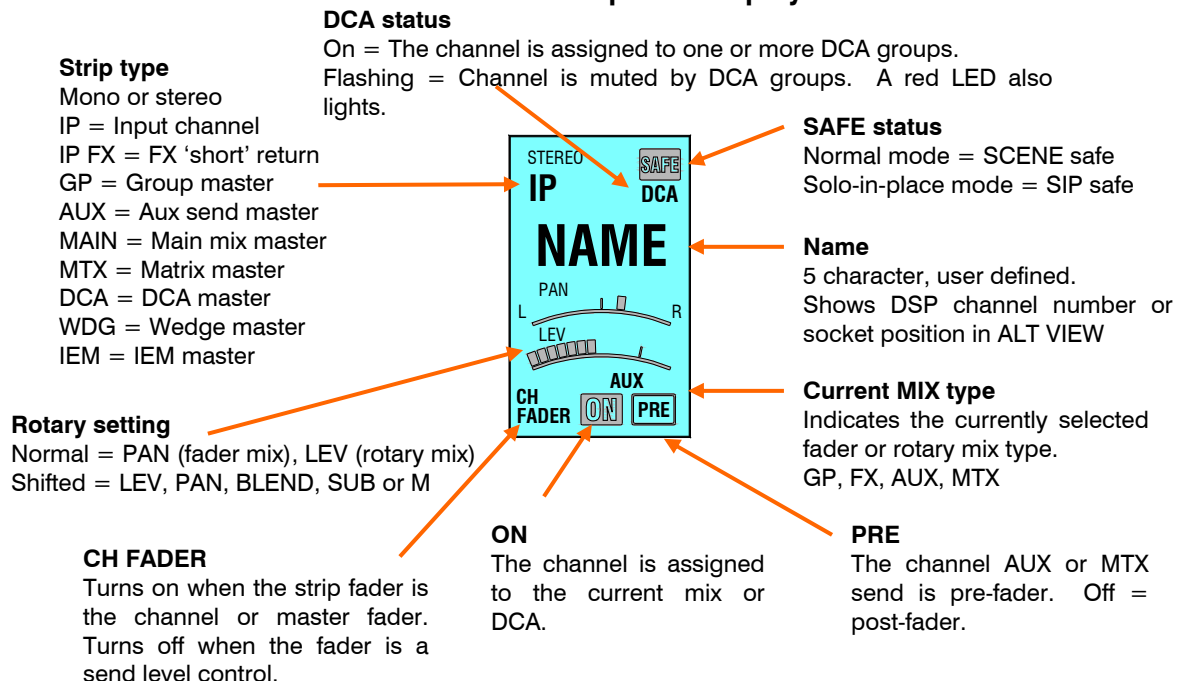

TouchScreen



The TouchScreen provides access to the FX, setup and utility functions and presents an alternative graphical view of the channel processing parameters.

Touch a parameter box and change its value using the **screen encoder**. To return to the root menu for any screen mode touch the Return button.

Note - To display the channel parameters on the screen make sure all the mode keys next to the screen are turned off, or press the CHANNEL PROCESSING key. A selected screen key overrides the parameter view.

Note - Do not leave the screen in **NAME/COLOUR, MIXRACK or SURFACE setup mode** as these change the function of the **SEL** keys.

Set your operating preferences

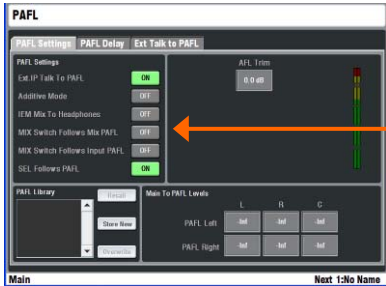

PAFL – Choose:

Additive or auto cancel mode when you press more than one PAFL key.

Options for the **MIX** and **SEL** keys to follow PAFL key presses. For example, pressing a single key can route the signal to the PAFL monitor, open its channel processing and present its mix and assignments on the strips.

PFL Trim to balance relative levels between PFL and AFL.

Main mix to PAFL monitor level. Set to '-inf' (off) to silence the monitor when no PAFL is selected.

Note – Input PAFL overrides any Output (mix) PAFL which overrides the Main mix.

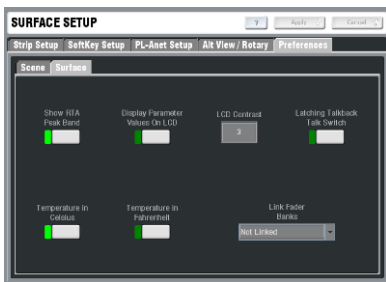

SURFACE / Preferences

Use this screen to set your preferences to:

Link the fader Banks when you press the Layer keys. Choose which Banks to link from the drop-down menu.

Display dB values on the strip LCDs when you move faders and encoders.

Set momentary or latching TALK switch operation. For example you could choose Latching if you are using a switched talkback microphone.

Enable the Scene Up/Down/GO recall keys near the faders.

Enable Scene edit confirmation popup screens to help prevent accidental overwriting of settings.

Choose the temperature display units in degree C or F.

Show the peak frequency activity on the RTA (real time analyzer) display.

Set the strip LCD contrast.

Note - To avoid accidental scene recall make sure Enable Scene Up/Down/Go is turned off unless you need to use the GO keys next to the faders. Choosing the Scene confirmation option can provide further protection.

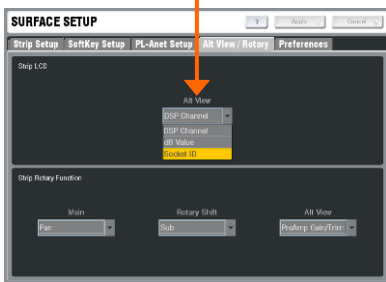

ALT VIEW key

Naming channels overwrites their channel numbers in the strip LCD displays. You can hold down the ALT VIEW key near the faders to temporarily view the numbers. Use the **SURFACE / Alt View Setup** screen to choose which information to display when ALT VIEW is pressed. You can select channel number, physical socket number or dB value.

You can also choose to access channel GAIN on the strip rotary controls while in ALT VIEW mode, and change the primary, shifted and alt functions.



FREEZE IN LAYERS key

You can temporarily 'freeze' (lock) a channel strip so that it remains in view when you switch through the fader layers. Hold down the FREEZE IN LAYERS key and press the strip **MIX** keys to freeze or unfreeze selected strips. The blue LEDs display which strips are frozen while the key is pressed.

Step 4 – Name and colour channels

Having chosen a Template show as your starting point, and set your operating preferences, you may wish to prepare for your show by naming your inputs, mixes and DCAs, and applying colour to help identify them by type or to highlight important channels. You can name channels with up to 5 characters entered from an on-screen touch keyboard. You can colour each or ranges of channels with one of 6 colours or no colour. This colour is displayed as the backlight to each strip LCD.

There are two ways to name and colour channels:

Channel Processing view

In normal mixing mode, press **SEL** to access the channel processing. Make sure all screen keys are turned off so that the channel parameters are displayed on the screen. Navigate to the name and colour screen:

Input Channels - **PREAMP** screen

Mix Masters - **EXT INPUT** screen

DCA Masters – Top toolbar



Name & Colour screen

Press the TouchScreen NAME & COLOUR key.

Strip Select / Single Strip Select - Press a strip **SEL** key. Touch Name to open the on-screen keypad. Touch Colour to select a colour. Touch Apply.

Strip Select / Block Strip Select - Press the first **SEL** key then the last in the range you want to colour. All green SEL indicators in the range light. Touch Colour to select the colour. Touch Apply.

Note – Naming is disabled in Block mode, apart from resetting a block of names to their channel numbers.

Channel Select - Select Channel Type and the range. Select Colour and press Apply.

Note - To restore the **SEL** keys to normal mixing mode turn off the NAME & COLOUR key.

Touch **Reset** to delete the name and restore the channel number.

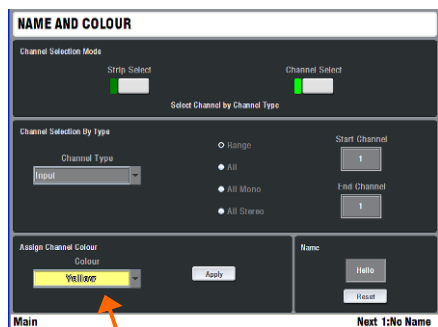

Quick Menu

A quick naming facility opens a second keypad to let you create and store up to 48x of your most often used names. To apply, press a strip **SEL** key and simply touch a name. Touch **Edit** to edit or create new names.

Note – The user defined quick names are stored in the Show memories. These get overwritten with the contents of the Show when it is recalled.

Step 5 – Work with the channel processing

Channel Processing Block



Press and hold to toggle 48V

* Processing **SEL** keys

Due to its compact size, the smaller iLive surfaces do not provide all the physical controls. Access these parameters using the TouchScreen.

Access the Preamp, EQ and dynamics

Press a strip **SEL** key. Press the key again to turn it off or press another to access a different channel.

* Press and hold any **SEL** key in the Processing Block to temporarily send it to the PAFL system to listen to and meter the signal at that point in the signal path.

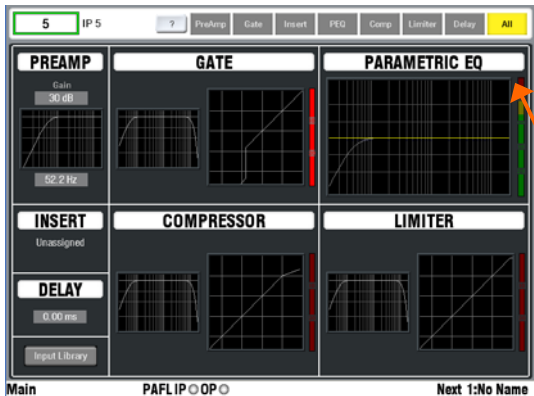

The **Channel Processing Block** displays the current settings for that channel. Controls illuminate if available.

The **TouchScreen** provides an alternative graphical view and access to the input and insert patching, delay setting and changing the name and colour. Touch the screen or press the processing **SEL** keys to open the different processing views. Touch **All** to return to the overview page.

Note - To view the processing parameters on the screen make sure all the screen keys are turned off. The **SEL** keys will not access the processing if you leave the screen in **NAME/COLOUR, MIXRACK** or **SURFACE**.

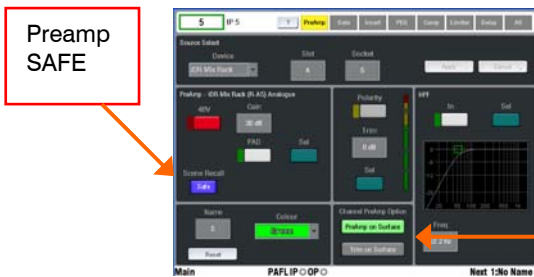

The **PREAMP** screen lets you patch the Source to the DSP channel, control the remote analogue mic preamp, adjust channel Trim and Polarity, set name and colour, and adjust the HPF (high pass filter).

Choose to present either the preamp controls (**Gain**, Pad, 48V, Polarity) or trim controls (**Trim**, Polarity) on the Surface **PREAMP** section. This lets both FOH and Monitor engineers work with their own independent trim controls once the Gain has been set. All channels may be globally set to present either the Preamp or Trim controls from the **MIXRACK SETUP / Mixer Pref** screen. Once set, individual channels may be changed from within their **PREAMP** screen.

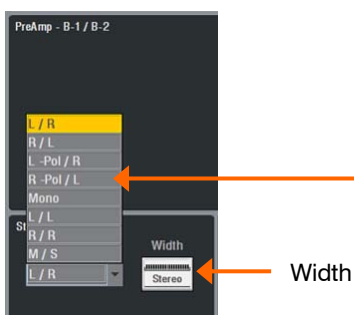

Stereo channels provide source **Mode** and **Width** controls.

- L / R = Normal stereo input
- R / L = Reversed stereo input
- L -Pol / R = Stereo with inverted Left polarity
- R -Pol / L = Reversed stereo with inverted Right
- Mono = Left and Right summed into mono
- L /L = Left as mono source to both sides
- R / R = Right as mono source to both sides
- M / S = Middle/Side decode to stereo

A 1/3 octave 28-band **GEQ** (graphic equaliser) is provided for each of the 32 mix outputs.



Low frequency bands 31, 40 and 50Hz added in V1.9.

Frequency response shows the combined response of the slider settings. Can show the response differences between the four GEQ models.

RTA display with Peak Band follows the PAFL signal. Go to **SURFACE SETUP / Preferences / Surface** to turn the Peak Band display option on or off.

Frequency bands can be adjusted by touching and dragging the sliders or turning the screen Rotary control.

GEQ Fader Flip to display and control the frequency bands using the faders.

GEQ Mode to choose one of four models that emulate classic equaliser types plus a unique hybrid response type:

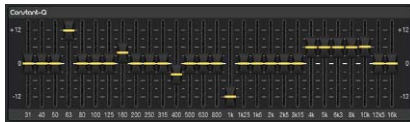

Constant-Q Symmetrical cut/boost where the width (Q) of the filter is a constant 1/3rd octave for any amount of cut or boost.

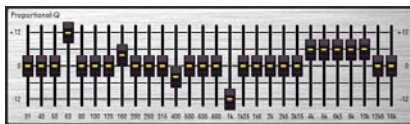

Proportional-Q Provides smooth wide Q for low cut/boost, which progressively tightens beyond 1/3rd octave for max boost/cut.

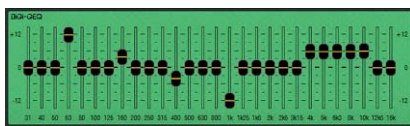

Digi-Q Gain and width are optimised to minimise band interaction and to provide a frequency response as close to the slider positions as possible.

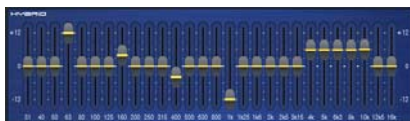

Hybrid Allen & Heath have developed the best of both worlds. The boost is proportional-Q for smooth and warm small boost settings. The cut is Constant-Q providing clinical 1/3rd Octave attenuation with minimal band interaction.

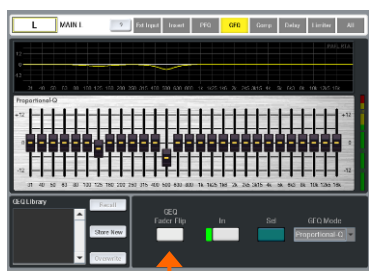

GEQ Fader Flip key



Mix master strip – Master fader or channel send level depending on active **MIX** key

Press **SEL** key to reset a band to '0'

GEQ on faders

Press a mix master **SEL** key to access the processing for that master. The GEQ is controlled from the screen or on the faders by pressing the Surface **GEQ FADER FLIP** key. Press again to toggle between frequency banks and return to normal fader mode.

In GEQ Fader Flip mode - The EQ frequencies are indicated on the strip LCDs above. The strip meters display the RTA (PAFL signal if one is selected). The red PK meters display the dominant frequency if this option has been set in the **SURFACE / Preferences** screen.

The fader on the right becomes the master or currently active send level for the mix. Hold down **ALT VIEW** to display the EQ dB settings on the strip LCDs. Press the strip **SEL** keys to reset individual frequency bands to 0dB.

Step 6 – Work with the mix



Press a strip **MIX** key.

The current mix status is displayed in the lower part of the strip LCDs. Mix sends are presented on faders or encoders. The current mix selected is displayed in the lower status bar of the screen.

Note – Make sure you are working with the correct mix. After making your adjustments remember to turn off the **MIX** key or return to your main mix. Turning off the MIX key automatically returns to the main mix.

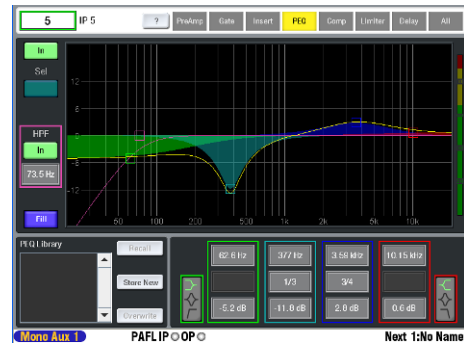

There are two ways to work with the mix:

Master **MIX** view - All sends to one master

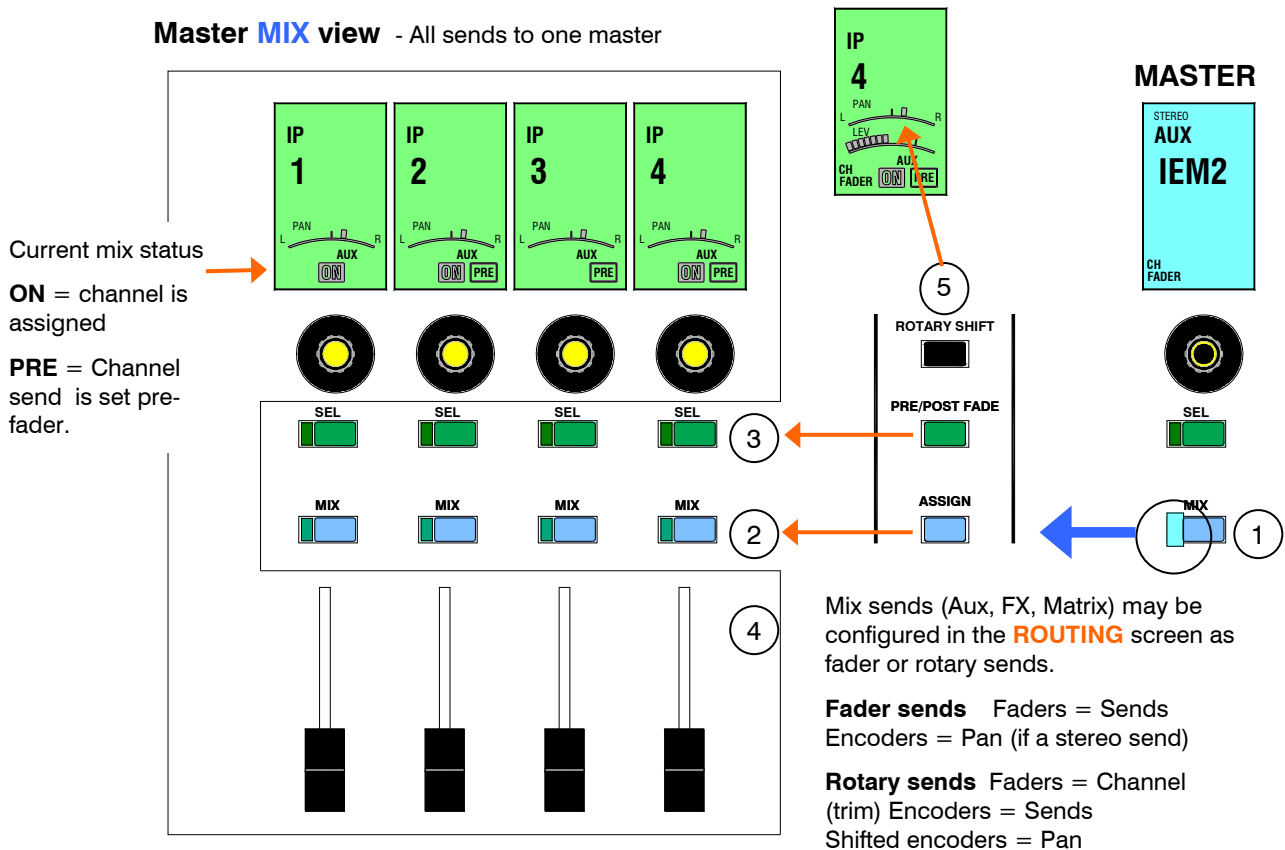

Channel MIX view - Sends to all masters from one channel

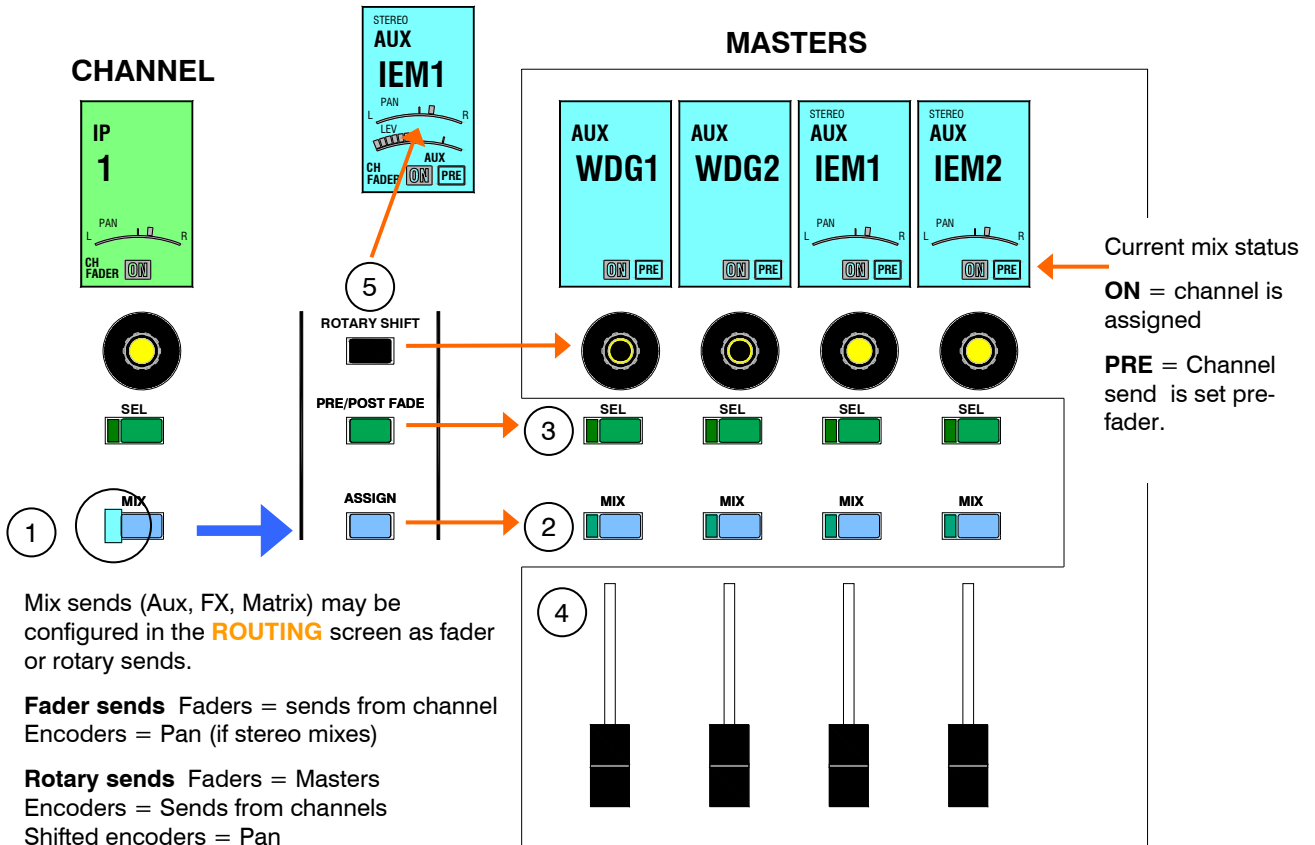

- 1 **Press a channel strip MIX key** Its sends are presented across the master strips.
- 2 **Assign the channels to each master** Hold down the ASSIGN key then press master MIX keys to assign to the available mixes. The ON icon displays in the LCDs.
- 3 **Set pre or post fader** To set the send to each master pre or post-fade, hold down the PRE/POST key and then press master SEL keys.
- 4 **Adjust the send levels** Aux, FX and matrix mixes can be configured for sends on faders or rotaries. For groups and DCAs (no send levels), the faders and encoders remain unaffected.
- 5 **Adjust the image** For stereo or multi output main mix use the master encoders to adjust the send Pan. Hold down ROTARY SHIFT and turn the encoder to adjust Pan for stereo mixes with encoder sends.

The ROUTING screen

Turn on the TouchScreen **ROUTING** page to display the assignment and routing information for the channel or master currently selected using a **SEL** key. This gives you access to advanced routing options as well as an alternative to using the **MIX** keys when adjusting sends and assignments.

In this screen you can view and change the channel mix and DCA assignments, fader/pan/aux/matrix send levels, pre/post fade settings and routing options.













Input - Also access the direct output level. Its source is globally set in the **MIXRACK SETUP** screen.

Aux - Also select the global channel send signal source for each mix from a drop down menu.

Aux, Matrix - Choose to mix sends using the faders or rotary encoders. This can be configured for each mix.

Note - Post-fader sends follow the fader level but get their source as set in this screen.



-  Spatial Modelling Reverberator
-  Gated Reverb
-  2 Tap Delay
-  Automatic Double Tracker
-  Chorus
-  Flanger
-  Symphonic Chorus
-  Hypabass Sub-harmonic Synthesis
-  12 Stage Phaser
-  Dynamic EQ
-  Multiband Compressor
-  Speaker Matrix Processor

Work with the FX

iLive works with FX in a similar way to analogue consoles, using a send and return path, for example reverb or delay effect. You can also configure inserted effects such as a flanger or reverb on a single channel.

Inserted FX Patch the FX unit into a channel or mix master signal path.

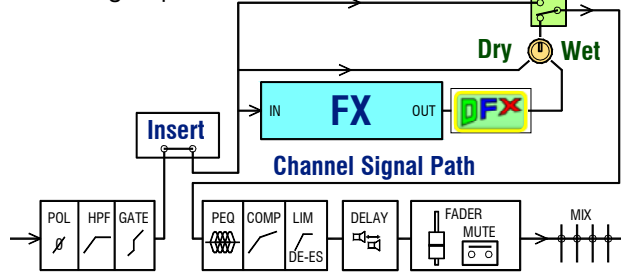

Send / Return FX Use a mix bus or channel Direct Output to send channel signals to the FX unit. Return the effect only (wet) signal via a stereo input or IP FX short return to the main mix. The effect adds to the unaffected (dry) signal routed directly to the main mix.

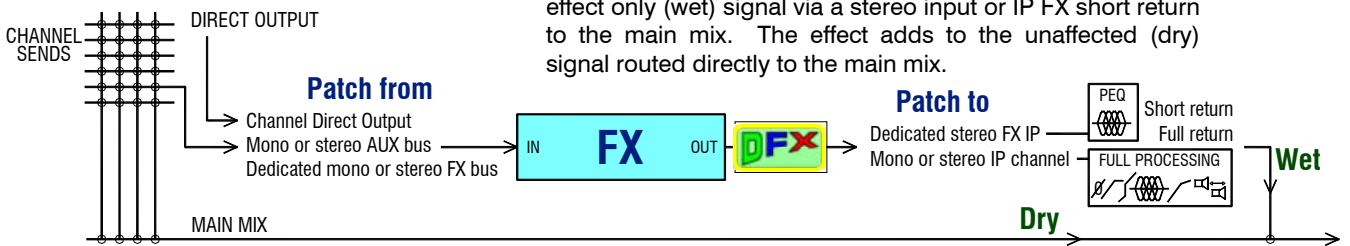

Use the **MIX** key to send to the FX as you would to an Aux.

To view and set up all 8 'RackExtra' FX select the TouchScreen **FX** page. Touch one of the 8 virtual rack slots shown across the top of the screen. Use the Library to load into an empty position or change an effect type.

The **Front Panel** view presents the FX parameters. Touch a parameter box or control and use the encoder to change the setting.

All FX units feature a **Dynamic FX Shaper DFX** which can use the source to Duck or Gate the effect automatically. This provides dynamic control of the effect, for example to prevent reverb or echo swamping the signal during loud, busy passages.

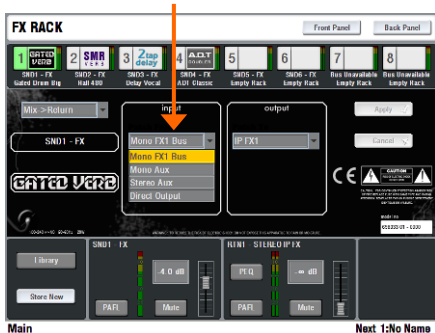

The **Back Panel** view lets you configure whether the effect is inserted into a channel or master, or set up as a send/return path. Choose the source feeding the FX and its output routing. The source can be patched from a dedicated FX send bus (if configured in the **Mix Config** screen), a mono or stereo Aux, or channel direct output (saves using up mix buses). The FX can be patched via a mono or stereo input channel or dedicated FX return 'short' channel which provides full routing and a PEQ, and is in addition to the 64 processing channels.

Press **SEL** on either an FX send master or return channel to open the FX screen if none of the screen keys is already selected. The channel Processing Block PEQ becomes available when selecting the return.

You can assign delay FX **tap tempo** to SoftKeys using the **SURFACE / SoftKey Setup** screen. Multiple tap keys may be assigned as these are linked to specific FX units. Choose whether to display the tempo on the associated LED.

Tap Tempo



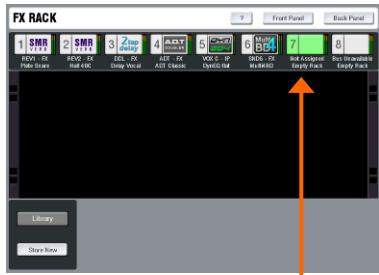

Load into an FX Rack slot

Dynamic Processing Firmware V1.9 introduced two powerful new processing tools to the FX Rack, the Dynamic EQ and the Multiband Compressor. These are typically found in recording and broadcast but becoming increasingly popular in live sound mixing. You can find out more about their application from specialist publications or the Internet.

Load these effects into available slots in the FX Rack and then **Insert** them into the required channels or mixes, for example a lead vocal channel or an instrument group. Patch the processor using the **FX** screen Back Panel view.

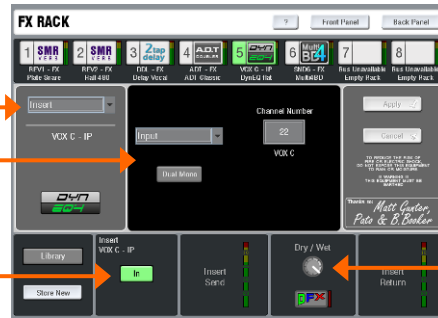

Back Panel view

Set as Insert

Choose channel to insert FX into

Switch FX in or out of circuit

Set to fully Wet

Multiband Compressor A compressor where the signal is split into several frequency bands and each is compressed according to the dynamics of the signal within that frequency range. This can reduce the 'pumping' effect common in single band compressors by preventing the compression affecting unrelated frequencies.

The FX Rack includes two multiband compressor types, **MultibD3** (3-band) and **MultibD4** (4-band), providing independent compression control over 3 or 4 different frequency bands.

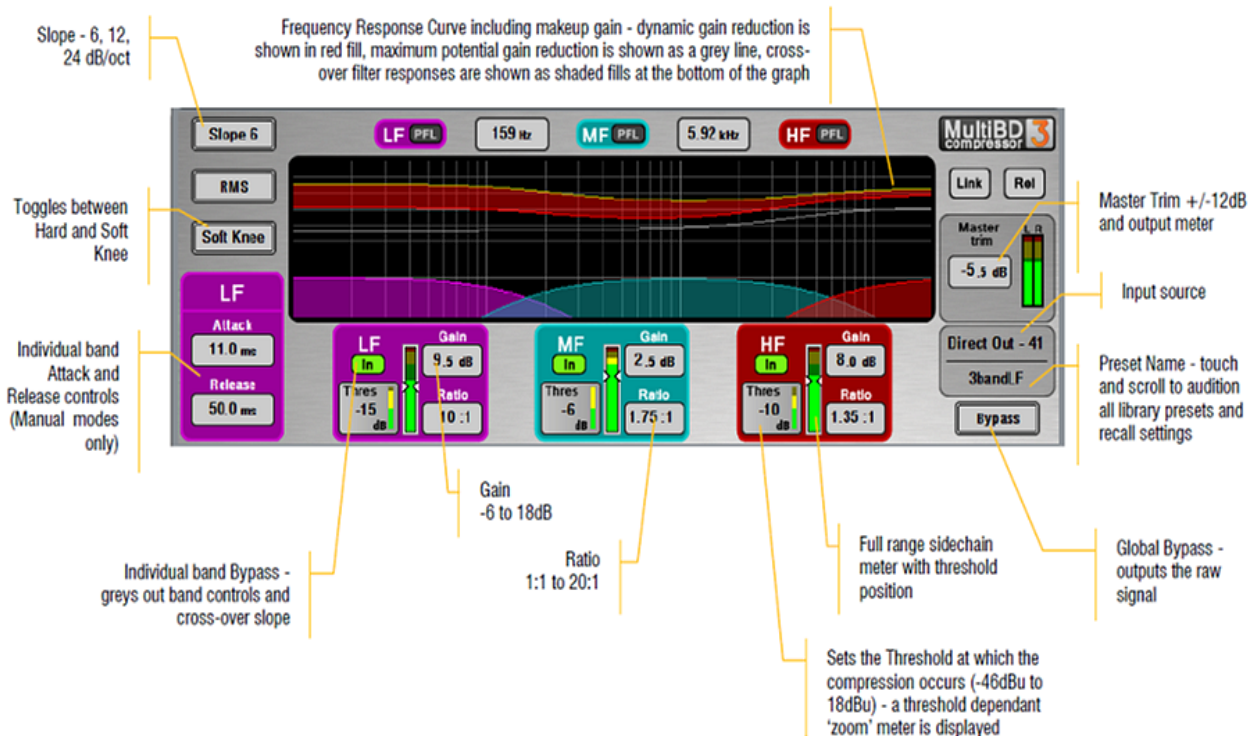

Dynamic EQ A 4-band parametric equaliser where the amount of cut or boost is dynamically changed according to the level of the signal above or below a threshold within each frequency band. You can choose whether to apply cut or boost when the signal goes above or below the threshold point.

Threshold View

The graph displays the 4 band frequency response, with the shaded fills showing dynamic activity and the solid outline showing maximum compression/expansion for each band - drag frequency points in the graph for tweaking

Input source

Preset Name - touch and scroll to audition all library presets and recall settings

Toggles between Threshold and Filter view

Comp/Exp sets the amount of gain for the band when the sidechain signal is above / below the threshold setting - centre position is flat 0dB

The horizontal gain meter shows dynamic metering of compression (green) and expansion (red)

Selects whether the Comp/Exp operates Above or Below the threshold

Full range, post filter sidechain meter with threshold position

Two switchable Attack/Release modes - Std is the standard release mode with smooth frequency conscious ballistic, Fast9 is a 'fast release' mode

Individual band Bypass - greys out band controls and response curve

Master Trim +/-12dB and output meter

Global Bypass - outputs the raw signal

Sets the Threshold at which the sidechain Comp/Exp occurs (-50dBu to 18dBu) - a threshold dependant 'zoom' meter is displayed

Filter View

Sets the sidechain filters for each band to either Cascade (fed from previous band) or Parallel (fed from common raw input)

Frequency control - all 4 bands full range 40Hz to 18kHz

Momentary Listen the sidechain filter through PFL

Width control - LF Shelf, Bell 2.1 to 1/9 oct

Width control - Bell 2.25 to 1/9 oct

Width control - Bell 2.25 to 1/9 oct

Width control - HF Shelf, Bell 2.1 to 1/9 oct

For information on the other FX available please refer to the [HELP MANUAL](#) available from the iLive Surface TouchScreen **UTILITY** menu and within the **Editor** software. Visit the [Allen & Heath web site](#) to download the [Understanding iLive FX V1.9](#) document.

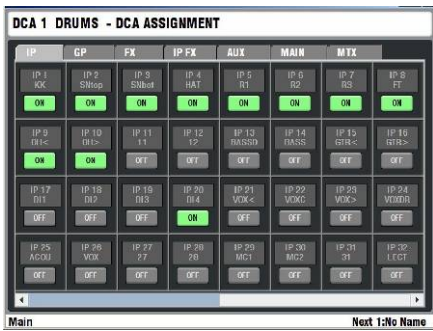

Using DCA groups

A DCA is the digital equivalent of the analogue console VCA group. iLive features 16 DCA groups.

To assign channels to a DCA group, select the DCA master **MIX** key. Hold down **ASSIGN** and press channel **MIX** keys to toggle ON or off. Alternatively open the DCA master **ROUTING** screen using its **SEL** key.

Note - Make sure you turn off the DCA master **MIX** key or select your usual **MIX** after you have finished assigning the groups.



Pressing a **DCA master PAFL** key mixes all assigned channels to the PAFL monitor.

Pressing a **DCA master MUTE** key mutes all channels assigned to the group. This affects all pre and post fade signals as if the channel mutes have been pressed

The strip DCA MUTE indicator lights and the LCD DCA icon flashes if the channel is muted by the DCA group.

DCA icon



DCA mute

Start with the **DCA master fader** set to '0' normal position. In this position the assigned channel levels are unaffected by the master. Raise the master to boost the assigned channel levels by up to +10dB. Lower the master to reduce the levels to fully off.

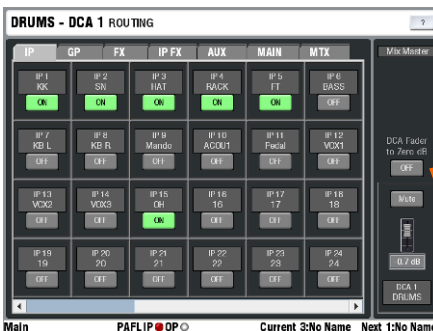

Using DCAs to create MUTE GROUPS

With 16 DCAs available you should have enough to use some for 'VCA' mixing, and configure others as mute groups.

A **Mute Group mode** can be set for each DCA group. Press the DCA master **SEL** key to open its TouchScreen view. Select the **ROUTING** screen. Touch the **DCA Fader to 0dB** button to set mute group mode. The master fader 'snaps' to 0dB.

Assign channels to the DCA group in the normal way. Use the DCA master **MUTE** key as the mute group master.

Mute Groups



Using the SoftKeys for Mute Groups

The DCA master MUTE keys may be assigned to the user **SOFT keys** next to the screen. This is useful once you have assigned the groups as you can hide its fader masters on a layer you are not using.

To assign SoftKeys use the **SURFACE / SoftKey Setup** screen.

The Template Shows provided with the iLive already have the Soft keys preconfigured as DCA group 1-8 mutes.

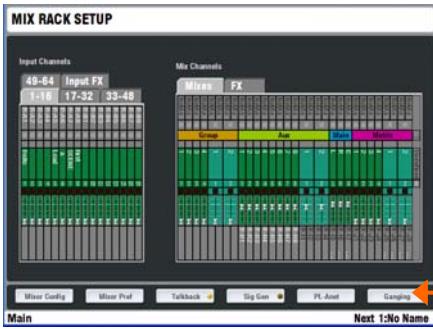

Channel Ganging

Ganging lets you link selected processing and mix parameters between input channels or masters, for example the EQ, gate and compressor of a stereo keyboard, or the GEQ of the L and R main mix. Ganging does not include the input Preamp (gain).

To enter Ganging Setup mode and view and assign ganged input or mix master channel parameters, select the TouchScreen **MIXRACK / Ganging** page.



Ganged channels must be compatible input or mix types. Up to **8 gangs** can be assigned with **up to 8 channels each**. The parameters available to be ganged are known as the 'attributes'. These include processing such as EQ and dynamics, delay, routing levels and assignments and mutes.

Touch a numbered Gang box in the left hand pane. Press the **SEL** key on the first channel strip you want to gang. Now touch the screen **Attributes** tab and highlight the parameters you want to gang. Touch Apply to accept the changes. Now press the **SEL** keys for the other channels you want to add to the gang.

The channels currently ganged are shown in the **Members** tab and on the related fader strip **SEL** keys. To remove gangs use the strip **SEL** keys or the Remove buttons in the Members tab.

Note – Do not leave the screen in the Ganging page. To restore normal operation of the strip **SEL** keys make sure you exit the Ganging setup screen.

COPY / PASTE / RESET

The Surface provides dedicated edit keys to let you quickly copy or reset settings.

Hold down the **COPY** key and then press a **SEL** or **MIX** key anywhere on the Surface to copy its related settings to the 'clipboard'. Now hold down the **PASTE** key and press the related **SEL** or **MIX** key on the channel or master strip you wish to copy the settings to. You can paste the clipboard settings into multiple channels.

To reset parameters to factory default hold down the **RESET** key and press the **SEL** or **MIX** key of the channel or master strip or processing block you wish to reset.

Settings that can be copied and reset:

Any Processing Block **SEL** - Parameters associated with that block, for example, just the Preamp, PEQ or compressor.

Channel, FX return or master strip **SEL** - All processing parameters associated with that channel, but not the Preamp settings or mix sends and assignments.

Channel or master strip **MIX** - Mix parameters including the send levels, group and DCA assignments, but not fader level, source or pre/post settings. For example, you can copy one Aux mix into another as a starting point for setting up that monitor mix.



Step 7 – Patch the sockets

The iLive features a built-in soft patchbay that lets you freely patch input and output sockets. The default Template Shows provide a standard patch as a useful starting point. You can change this patching to suit your application and store it in the Scene and Show memories.

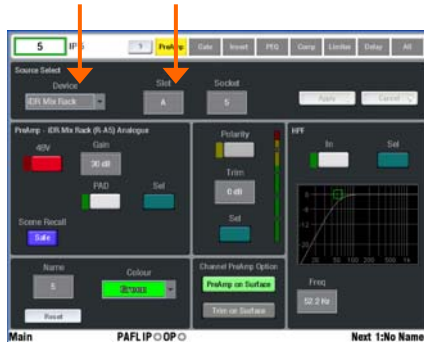

Signals available to patch:

- Mono/St Group
- Mono/St Aux
- Main mix
- Mono/St Matrix
- Input channel direct output
- PAFL monitor L, R
- MixRack inputs (mic split)
- Bus out 1-32
- Wedge/IEM monitor
- ACE link (Port A)
- Port B (network option)

Select the tab to view the sockets you wish to patch.

Touch the socket to view its current patch or to select it for patching.

Select source from the drop-down menu and number box.

Touch Apply to confirm the change

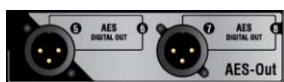

View and patch channel INPUT sockets

Press **SEL** for an input channel and view its screen **PREAMP** page (Make sure the keys next to the TouchScreen are turned off). Use the Source Select boxes at the top of the screen to view and change the input socket feeding the channel. The sockets are identified by Device (Rack, Surface or Port B), Slot (position) and Socket (number).

View and patch OUTPUT sockets

Select the TouchScreen **OUTPUTS** screen. Touch the tab to select which output sockets to patch - MixRack, Surface or Port B (if the option is fitted).

Touch **Single** to select and patch a signal to one output.

Touch **Range** to patch related signals to a range of sockets.

Touch Apply after each change.

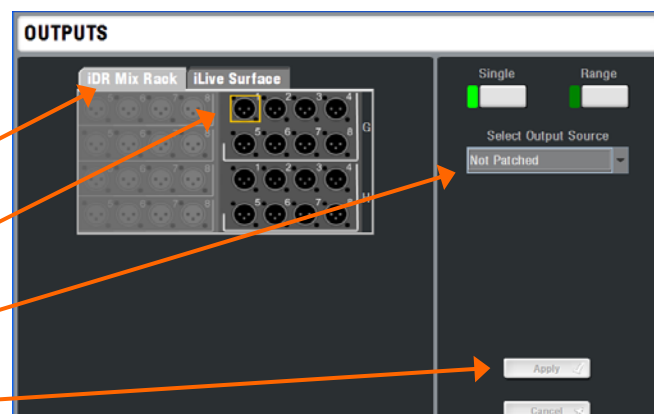

If you have the AES digital output card option fitted then assign these in the same way. Assign a pair of outputs to each AES socket, for example 7 and 8.

Patching INSERTS

In most cases you do not need to insert outboard processing. However, if required you can assign output and input sockets as insert sends and returns for situations where an engineer wants to use a particular device. Any number of inserts may be assigned.

Press a channel or mix **SEL** key. Return to the top level parameter screen. Touch the **INSERT** panel to open the INSERT screen.

Use the drop down menus to assign the send and return Devices. After selecting both, touch Apply. Select the required Operating Level, typically +4dBu.

Note - Once a socket is assigned as an insert it is no longer available for other purposes. Unassign the insert to re-use the sockets.

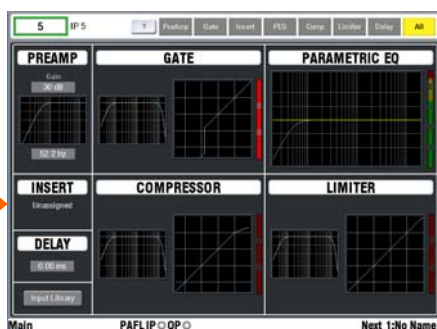

Step 8 – Customise your configuration

Once you have familiarised yourself with the operation of the iLive through using a Template Show, you may wish to take advantage of its unique flexibility by reconfiguring the channel and master strip layout, DSP mix bus and stereo channel architecture, soft key assignments and more. You can 'design' your own console to suit the way you like to work.

Note - These instructions are intended to get you started. For more information on configuring the iLive and using its advanced features please refer to the TouchScreen [HELP manual](#) and other information which you can download from the Allen & Heath web site.

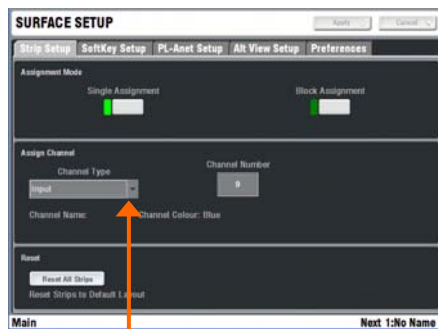

Unused (blank)
Input channel
Mono/St Group
Mono/St Aux
Mono/St FX send
Main
Mono/St Matrix
Input FX return
DCA master
Wedge/IEM master

To change the FADER STRIP LAYOUT

Any input, mix master, DCA master or Wedge/IEM master can be assigned to any strip on any layer in any Bank.

Go to the **SURFACE SETUP / Strip Setup** screen.

Select **Single** to assign a single strip. Press a channel **SEL** key. Assign Channel Type using the drop down menu. Touch Channel Number and use the encoder to scroll to the number you want. Press Apply.

Select **Block** to assign a range of strips. Press the start strip **SEL** key. Press the end strip **SEL** key. Assign the channel type and start number as above.

Note - The strip **SEL** keys are used to select which strips to assign while in this mode. Make sure you exit SETUP mode to restore normal channel processing selection.



To change the MIX BUS configuration

Press the TouchScreen **MIXRACK** key to view the current channel settings and assignments of the 32 mix buses.

MIXRACK / Mixer Config / Mix Config - Use this screen to change the mix bus configuration.

Configure the 32 mix buses as a combination of mono or stereo Groups, Auxes, FX sends, Main mix and Matrix. Configure all or as many buses as you need. Counters keep a check on the number of buses, mix outputs and FX sends remaining. Press Apply when finished.

For monitor mixing, you can also choose whether to apply processing to the engineer's Wedge or IEM monitor master when using the system as a dedicated Monitor console.

Note - Reconfiguring the channel stereo and mix bus architecture makes major changes to the system DSP and overwrites related settings. These changes can take up to 1 minute to process and should be made during system setup and not during the show.

Note - Changing the DSP architecture resets the mix and channel parameters. If you want to keep your settings store these first as a **Scene** memory. Recall the Scene after making your changes.

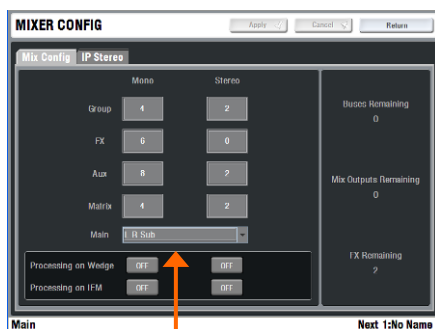

None - No main mix, eg. Monitor mixer
M - Mono
LR - Stereo
LRSub - 3way mix with separate sub mix
LRM - 3way mix with send to a mono fill
LCR - Conventional LCR panning
LCRSub - LCR with separate sub mix
LCRM - LCR with send to mono fill
LCRplus - LCR with pan and blend control
Radio LRM - For broadcast application

Store settings before changing configuration

Step 9 - Save your settings

iLive provides different types of memory to store your settings. Back up your settings to the onboard memories or archive them to your PC via USB key. For more information refer to the on screen [HELP manual](#).

Power down memory

You do not need to store settings before switching the system off. iLive remembers its last settings on power down and restores these when the system is next turned on. Your settings are restored even if mains power is lost without warning.

User Profiles

iLive lets you set up and work with up to 8 'User Profiles'. You can set permissions and a password for each to restrict operator access to certain functions.

The 'Admin' user (Administrator) has access to all functions and can set permissions and allocate passwords if required for the other users. Up to 7 guest users may be configured and activated.

To set up User Profiles go to the TouchScreen **UTILITY / Configuration / Edit User Profiles** page. Touch a User button. Use the onscreen keypad to enter a user Name and add a Comment. Set a Password if required. Touch Set Permissions to enable or disable access to certain functions. You can also assign a User Scene which will recall automatically when the user logs in. Select No User Scene if none is required. Activate any user profiles you want to appear in the Change User or log in screen.

Note - Only set passwords if you really need to. Make sure you keep a log of all passwords allocated. Clearing passwords required resetting internal jumpers and clearing the memories.

To log in as a different user go to the TouchScreen **UTILITY** page and touch the Change User button. If a password has been set then you are prompted to enter it when you turn the system on or lock or unlock the Surface.

Libraries

You can name, store and recall parameter settings as User libraries, or recall factory presets from the Library pane in each processing screen.

Libraries can be archived to computer or transferred between iLive systems using a USB key. Press the TouchScreen **UTILITY / Configuration / Library Manager** key to work with the USB library function. If you plug in a USB key with libraries available these will be listed in the related Library screens. You do not need to copy them to the Surface to work with them. Copy libraries from the iLive to the USB key to archive or transfer them.

Note - For iLive to see the Libraries on your USB key they should be placed in an '**allenheath \ libraries**' folder in the root directory of your key. If libraries have been previously transferred from an iLive to the key then the folder should exist already.



Library types:

PEQ
GEQ
Noise Gate
Compressor
Limiter/De-esser
Full input channel processing
Full mix channel processing
FX emulations
PL-Anet setup

Scene memories

iLive has 250 Scene memories. These are 'snapshots' of all or a selection of the live mixing parameters. They do not store the DSP bus configuration and user preferences.

Before starting go to the **SURFACE / Preferences** screen and set the options to enable or disable the Scene Up/Down/Go keys, and turn on or off the Scene Editing Confirmation popup box. For the most secure operation we recommend that you disable these keys and turn on the confirmation popups.

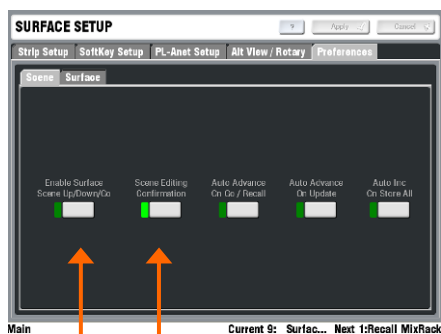

Preferences

Recall Scene

Select the **SCENE** screen. Highlight a Scene in the left hand list. Touch **Name** to open the onscreen keypad and enter a name with up to 14 characters. Touch Description to add a comment with up to 32 characters.

The quickest way to work with Scenes is to store everything. Touch **Store All** to store all parameters to the Scene. Touch **Recall** to overwrite the current iLive settings with the contents of the memory. Once a Scene has contents stored a green tick is displayed next to its name.

Note – To avoid losing important settings take care when storing or recalling Scenes.

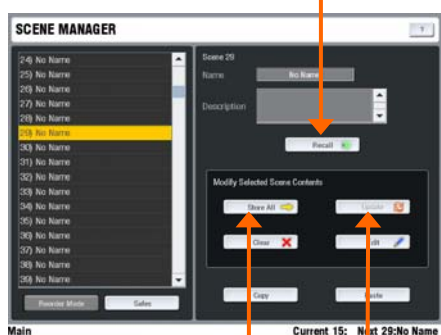

Store all settings

Update existing contents of Scene

For more advanced applications you can choose what parameters to put into a Scene so that only those are overwritten. Touch **Edit** To open the list of available parameters. Use the + and - buttons to expand or collapse the list, and the View buttons to select parameters by type or channel. You can make Single or Multiple selections. Highlight your selection and touch Add to add them to the Scene list on the right. You can add and remove items from the Scene, and update items already in the Scene with the current console settings. When you have finished editing the contents Return to the Scene Manager page.

Touch **Update** to update just the existing contents of a Scene with the current console settings. Unlike Store All this does not add everything to the Scene.

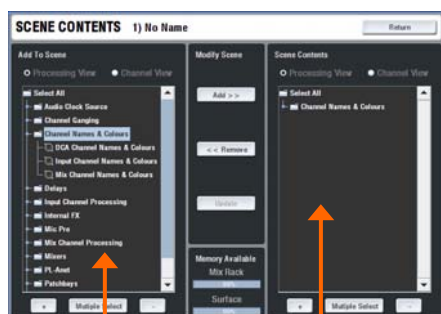

Settings in the Scene

Settings available to add

You can copy, paste and delete Scenes. Highlight a Scene in the list and touch **Copy**. Highlight another Scene and touch **Paste**. The contents of the first Scene are pasted into the second. The name is not copied. If that Scene was empty a green tick will now appear. You can paste the Scene into multiple locations. When you **Delete** a Scene its contents are removed and the name reverts to 'No Name'.

Tip - You can use copy/paste to quickly set up several Scenes with the same content list, and then use Update to store different parameter settings for each as the sound check or show progresses.

Reorder mode - Lets you re-arrange the 250 Scenes by moving, copying, deleting them or clearing their contents.

Select single or multiple Scenes. Use the TouchScreen encoder to highlight the new position when moving or copying Scenes. Touch Apply to confirm the edit.

Move – Repositions Scenes in the list.

Copy – Copies the name and contents to other Scenes in the list.

Remove – Choose to clear the name and contents of Scenes, or to delete them from the list.

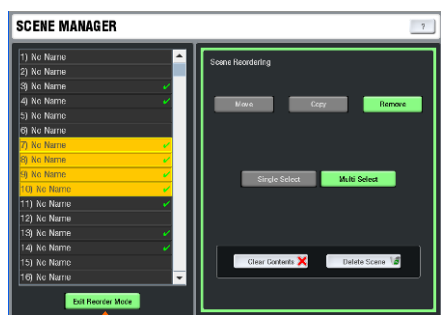

Flip between Normal and Reorder mode



Scene Recall Safes lets you make selected input channels, mix and DCA masters 'safe' so that their parameters are not overwritten when a Scene is recalled. Hold down the Surface **SCENE SAFES** key and press the strip **MIX** keys on channels you want to make safe. The **SAFE** icon in the strip LCDs turns on for channels made safe. You can also right click the MIX or SEL button in the channel windows in **Editor** to access the Safe setting.

Examples of channels to make Safe:

Walk-in music - Background music such as CD or iPod played while the audience arrives or while the next band is being set up on stage. You could recall the Scene for the band without interrupting the intermission music.

Continuity channels - One or more presenters talking to the audience while another act is getting ready on stage. Recalling the Scene for the act will not affect or interrupt the presenters.

Mute (DCA) Groups - It can be useful to set up a few 'safe' mute groups to mute a band or act during changeover. Making them safe prevents any unexpected noises on recalling a Scene where channels were left unmuted after sound check.



Preamp Safes The mic preamp is automatically included in channels made safe using the **SAFES** key. If you do not want to make the preamp safe, for example because you have patched it to more than one input channel, you can change its safe status using the **Preamp** screen **Safe** button. Alternatively you can make just the preamp Safe, for example if you have had to make a gain change to a preamp which is recalled in several Scenes.

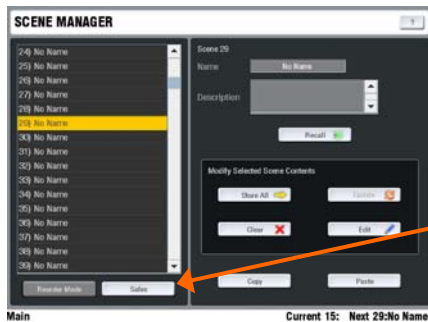

Safes Map Selected parameters on selected channels and masters can be made safe from Scene recall from within the Scenes Safes page. Touch the Safes button to open the page.



Navigate the tabs to find the parameters and channels you wish to make safe. Touch a channel number in the left column to make all parameters for that channel safe. Touch a parameter button in the top row to make that parameter safe across all channels. Use the buttons at the top to set or reset all items on that page.

The Patchbay item can be found in the Other tab.

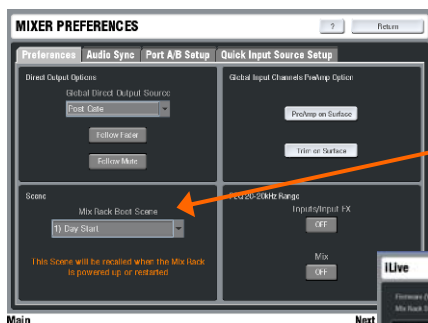

MixRack Boot Scene For fixed installations where it is required that parameters are reset to a known starting point when the system is powered up or restarted. This affects MixRack parameters only, not the Surface. Any Scene with all or partial parameters may be set as the Boot Scene from the **MIXRACK SETUP / Mixer Pref / Preferences** screen.

The **Home** screen makes it clear when this option is enabled. Only set a Boot Scene if it is needed.



Show memories

You can archive your configuration as a Show memory. **Show memories overwrite all the settings.** These include:

- The system configuration
- All current parameters
- All 250 Scenes
- User preferences.

Factory default Template shows

Archive settings as a User Show



User Show list

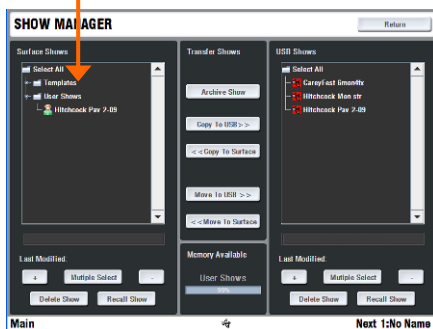

Show open with its Scenes listed

Scene transfer Filter



Shows are stored on the TouchScreen computer within the Surface or on the Editor laptop and can be transferred between systems using a USB key.

To work with the Show memories go to the **UTILITY / Configuration / Show Manager** screen.

Template Shows – Template Shows are factory defaults and cannot be deleted. They give you a quick starting point for mixing with iLive and can be edited to create your own User shows.

To recall a Show, highlight the Show in the list and then touch the Recall button. Confirm the action. It can take several minutes for a Show to recall.

User Shows - To archive your settings as a User Show touch the Archive Show button. Type in a name using the onscreen keypad. Press Enter to archive the show. This takes a few seconds to complete.

To overwrite an existing User Show highlight it in the list and touch Archive. The keypad opens with its name displayed. Either type in a new name to archive it as a different show, or just press Enter to overwrite the existing show.

Note - Recalling a show overwrites all the system settings and can change your mix architecture and patching. Make sure existing settings are archived first if you want to keep them to use again in the future. Show recall can take several minutes depending on how much information is stored.

Note - Show recall should only be used when reconfiguring your system for a different event. This would typically be done once for the event. Use the Scene memories rather than Shows to recall settings for different scenes in a theatre performance, bands at a music festival, day to day setups in a church, and so on.

Note - For iLive to see the Shows on your USB key they should be placed in an 'allenheath \ shows' folder in the root directory of your key. If you have previously archived Shows to the key using an iLive then this folder should have already been created.

USB Scene Transfer – Use this function in the **UTILITY / Configuration** screen for situations where you want to import settings from a guest engineer's USB key but do not want to overwrite all your system settings.

USB Scene Transfer displays all the User Shows available on the USB key. Open a Show to list the Scenes stored within. The 'Last Settings' item is the setup that was current when the Show was archived.

Set the Transfer Filter to **block** the settings you want to protect, for example the output patching and master strip assignments in a festival situation.

You can copy from the USB key to iLive or iLive to the key through the filter. This overwrites a Scene location but does not recall its settings.

Dual-Rack input expansion

Two MixRacks may be connected in Dual-Rack mode to expand the number of input channels from 64 to 128. The number of physical inputs available depends on which MixRacks are used. This does not expand the number of mix buses.

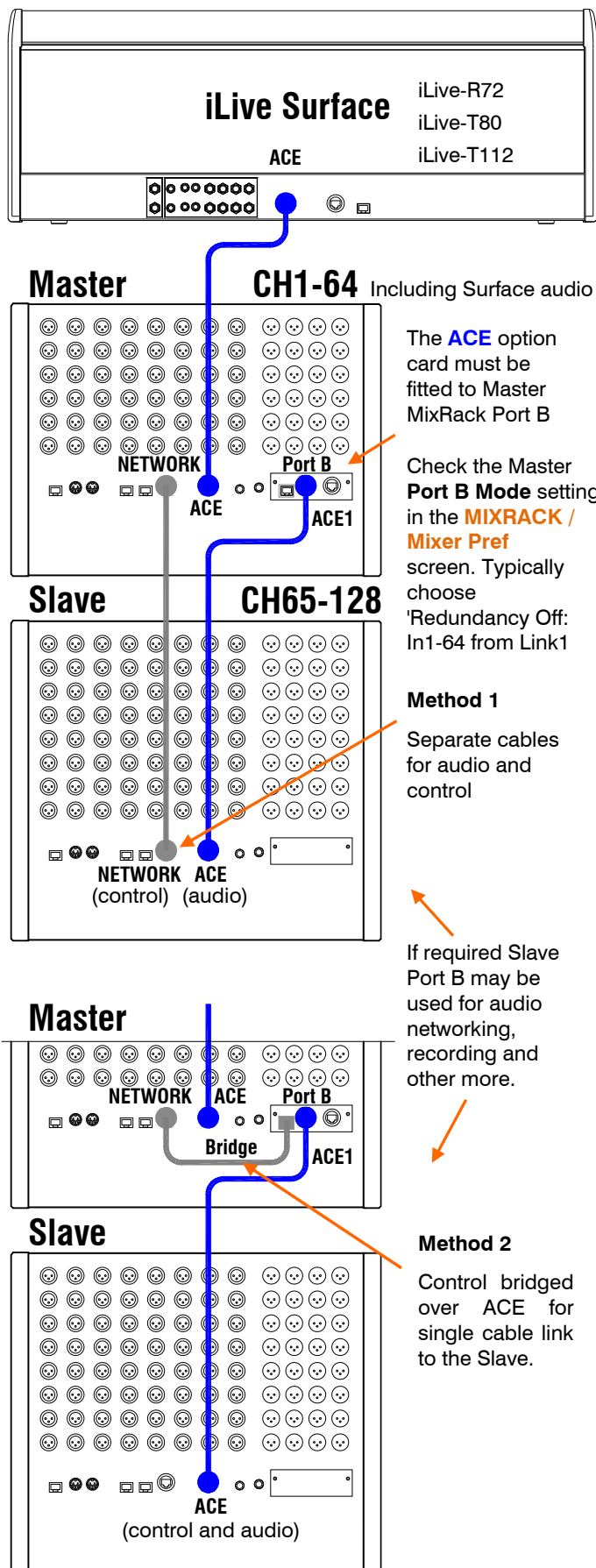

Step 1: Network settings

Important note: The Master and Slave MixRacks must have unique IP addresses and Unit Names.

Make sure both addresses and names have been set before the two MixRacks are connected together.

Set these in **Network Settings**

For example: 192.168.1.1 "Master 1-64"
192.168.1.4 "Slave 65-128"

Step 2: Connect Dual-Rack system

Connect the Surface to the Master MixRack using 1x CAT5 cable in ACE Port A.

Link the Master and Slave MixRacks using 2x CAT5 cables. According to your preference, choose:

Method 1 – Connect a Master Network port to a Slave Network port. Connect Master Port B ACE 1 to Slave Port A ACE. or

Method 2 – Link a Master Network socket to its Port B Bridge socket. Then use one cable to connect Master Port B ACE 1 to Slave port A ACE.

Refer to Allen & Heath web site for recommended cable type and maximum length.

Step 3: Set up Dual-Rack system

Using the Surface TouchScreen go to **Utility / Network / Dual MixRack Setup**.

Touch **Add Slave**. Highlight a MixRack in the list to add as Slave.

Touch **Inspect**. Details of the MixRack are displayed. Check that the firmware is compatible.

Touch **Apply** to add the MixRack as a Slave. The MixRack reboots and resets its parameters.

Note:

- Channels 1-64 are sourced from the Master MixRack (Preamps cannot be mapped across MixRacks).
- Channels 65-128 are sourced from the Slave MixRack.
- Surface audio can only be assigned between channels 1- 64 (connects to Master MixRack).
- Each MixRack processes its own channels 1-64 or 65-128.
- The Master MixRack processes the 32 buses.
- FX may be inserted on Master channels 1-64 only.
- Channels cannot be ganged across MixRacks.
- The Reset Network Settings recessed switch restores default single MixRack operation.

System example

The following is just one of many system combinations possible with iLive. Here, two MixRacks are linked for digital mic split from one set of preamps feeding two independent mixers, one for FOH, the other for on-stage monitors. One engineer uses a compact T80 Surface to mix the house sound, the other uses a wireless laptop to mix monitors on stage.

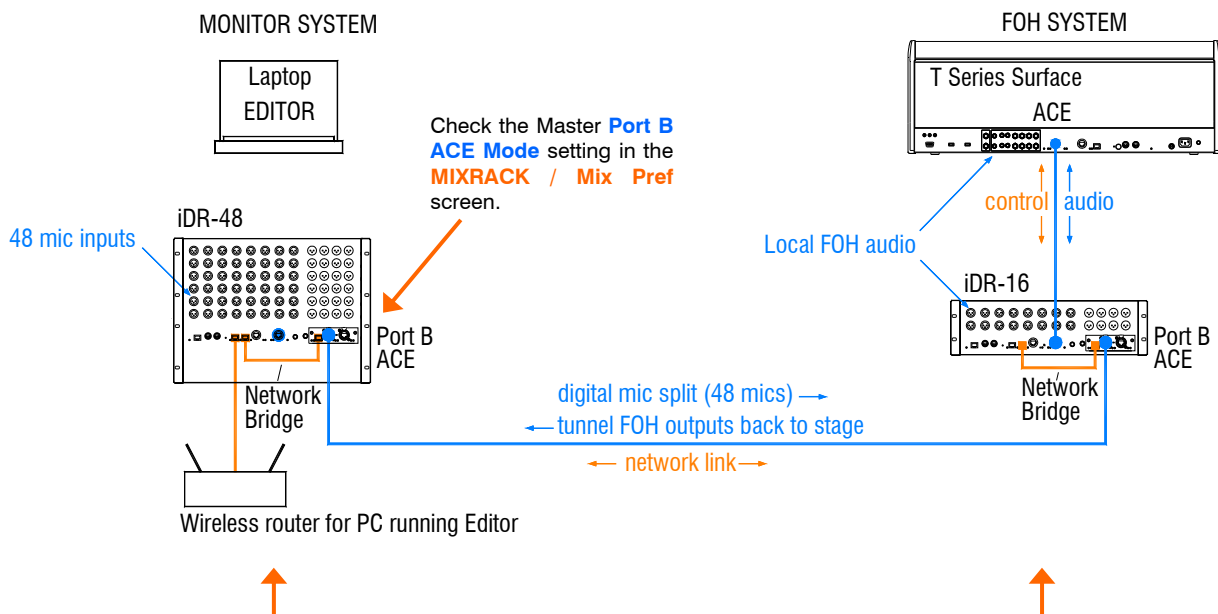

Master system The iDR-48 provides a large number of mic inputs for sources on stage, and plenty of outputs to feed the wedge and IEM monitors.

Port B provides a **digital mic splitter**. In this example ACE™ is used. Alternatives are MADI or Dante. Patch the **MixRack Inputs** to Port B using the **OUTPUTS** screen. This takes the signal straight after the preamp so that each engineer has their own channel Trim control.

The NETWORK is shown bridged at both ends to the ACE™ cards using short CAT5 cables (part number AH7812). This is only necessary if you want your laptop to be able to access both systems via the wireless router. Make sure each MixRack, Surface and network device has a unique IP address. If you need just audio then leave the Bridge sockets unplugged.

This example shows a compact two engineer system with wireless laptop or iPad controlling monitor mixes. Alternatively you could connect another Surface to the iDR-48 so that each engineer works with their own Surface. A laptop or iPad can be added at either or both ends in addition to or instead of the Surface.

Slave system The small iDR-16 with its 64x32 DSP can mix a full 64 channels even though it has just 16 inputs. It gets the 48 mics via the Port B digital split. The T80 provides 8 more inputs at the Surface for local sources. With the 8 internal FX returns this is the equivalent of a 64 channel analogue mixer.

Because the 48 mic sources are received via Port B it is necessary to **patch Port B inputs** to the iDR-16 channels instead of the local sockets. Do this for individual channels using their **PREAMP** screens, or for a range of channels from the **MIXRACK SETUP / Mix Pref** screen Quick Input Setup function.

Feeds to the house PA can be routed from FOH or **tunnelled** back to the stage via Port B. These are patched to Port B at the sending end and to the iDR-48 sockets at the receiving end using the **OUTPUTS** screen.

The **audio clock** is set to sync off Remote Port B derived from the iDR-48 master. Set this using the **MIXRACK SETUP / Mix Pref** screen.

Find out more about using the iLive

We hope that this guide has given you a quick start to mixing with the iLive. Take some quiet time to familiarise yourself with the more advanced functions and utility screens. For further information please refer to the TouchScreen **HELP manual** in the **UTILITY** screen and other user resources which can be downloaded from the Allen & Heath web site. Share experiences and tips with other iLive users by visiting our online User Forum.

Happy mixing!

iLive-R72 Rack Ears - Fitting Instructions

Desk Top - Side Trims Fitted

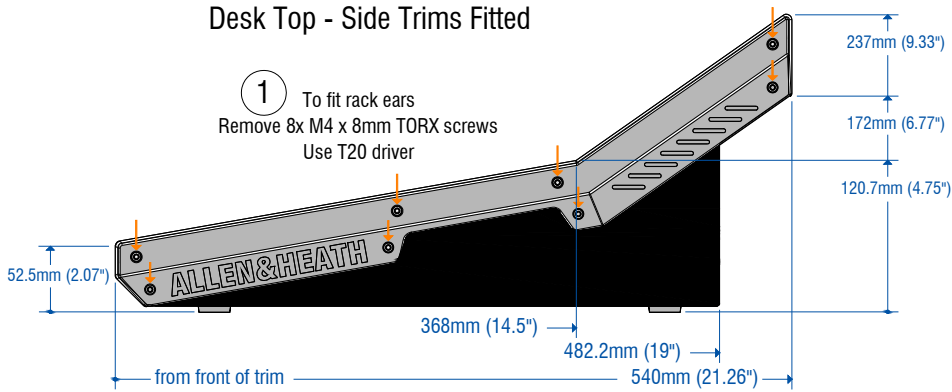

Rack Ears - Flush Mounted

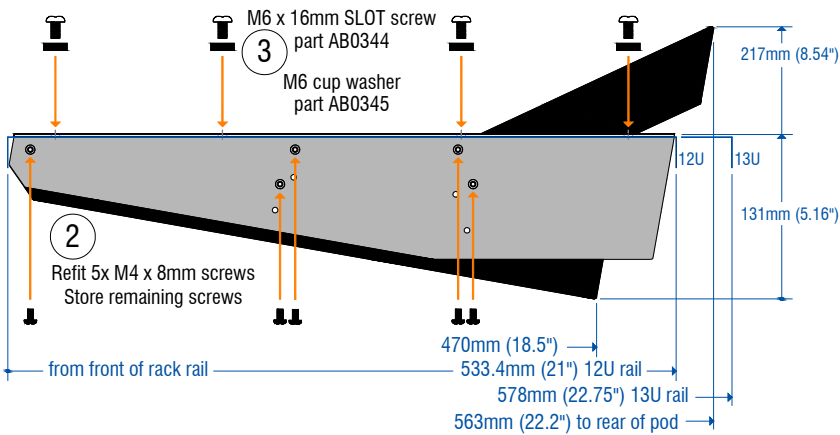

The iLive-R72 Surface can be configured for desk top, flight case, 19" rack or furniture installation. The plastic side trims can be removed and replaced with the metal rack ears provided. A minimum 12U rack space is needed. More may be needed depending on connector access requirements.

Two rack ear positions are available – either flush with the control panel or angled at 16 degrees for a lower profile fit.

When rack mounting ensure adequate ventilation and space for the connectors, cables and lamp fitting at the rear.

Note – Due to the height of the TouchScreen a rack case with a deep lid is required. Many standard off-the-shelf equipment cases are not intended for consoles such as the iLive. However, most flight case manufacturers can provide custom cases to suit different mixer models.

Rack Ears - Angled

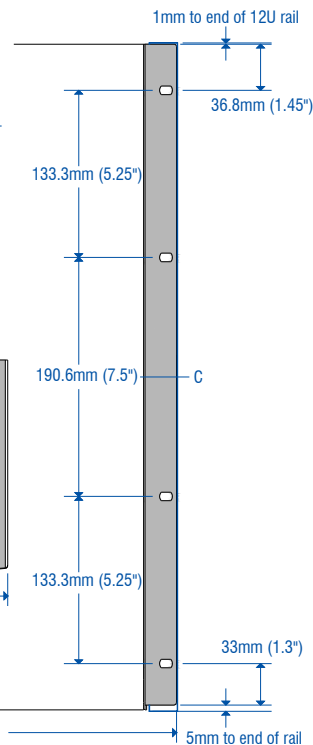
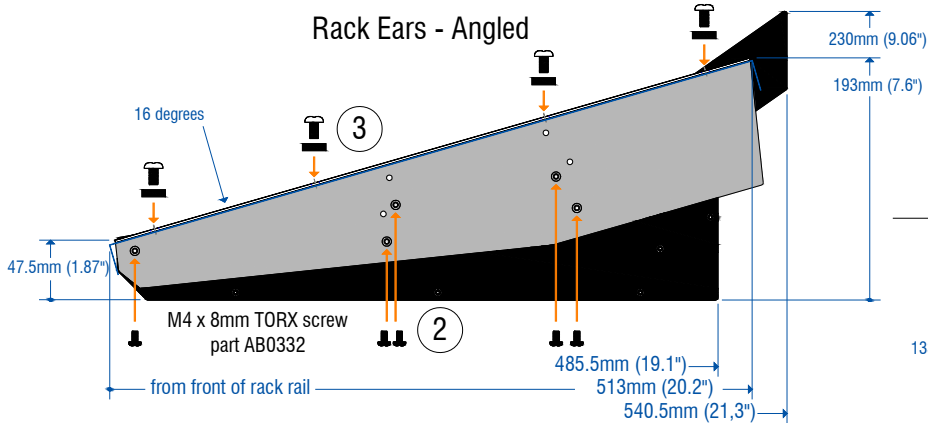

Dimensions

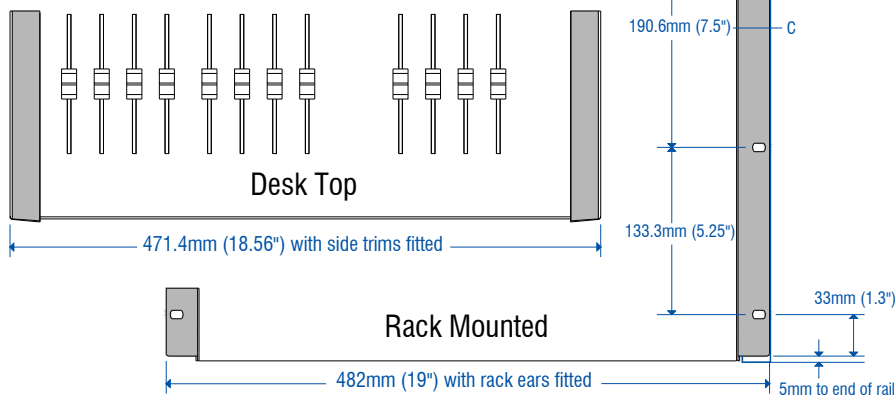

Fixed Format iLive - Default Template Show 1_FOH-LRSub

Dedicated Front-of-House, or mixing monitors from FOH

3-way main mix LR+Sub, 8 Groups, 12 Auxes, 8 FX, 8 Matrix, 16 DCA Groups
Assigned to surface: LR+Sub, 8 Groups, 12 Auxes, 4 FX, 8 Matrix, 5 DCA Groups

Bus configuration	LRSub main mix	Channels	CH1 - 60 = mono
	4 mono, 2 stereo Groups		CH61/62, 63/64 = stereo
	8 mono, 2 stereo Auxes		
	6 mono FX sends		
	4 mono, 2 stereo Matrix	FX	6 Send>Return stereo FX
	16 DCAs		2 insertable stereo FX

You can change the configuration and layout to suit your application
Name and archive your new configuration as a User Show

Fader layout - Inputs on left fader banks, Masters on right bank as shown below:

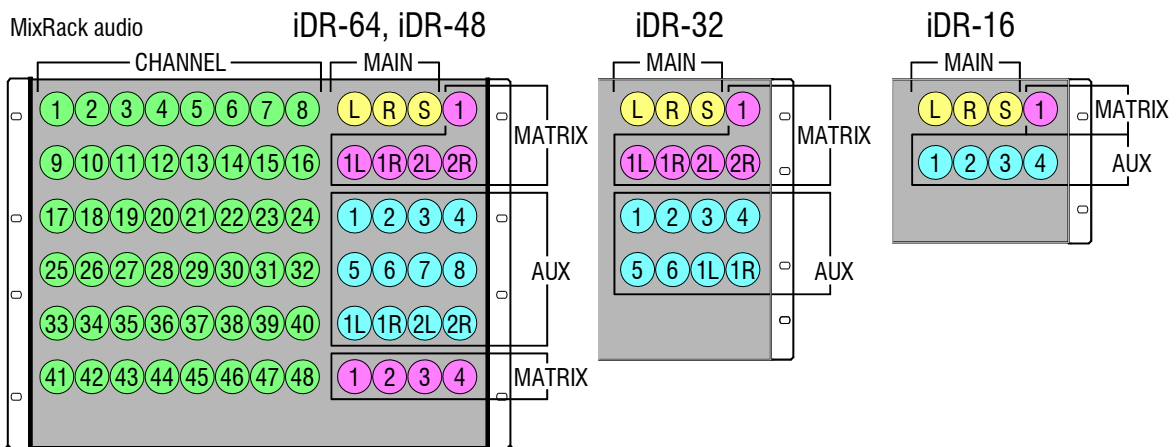
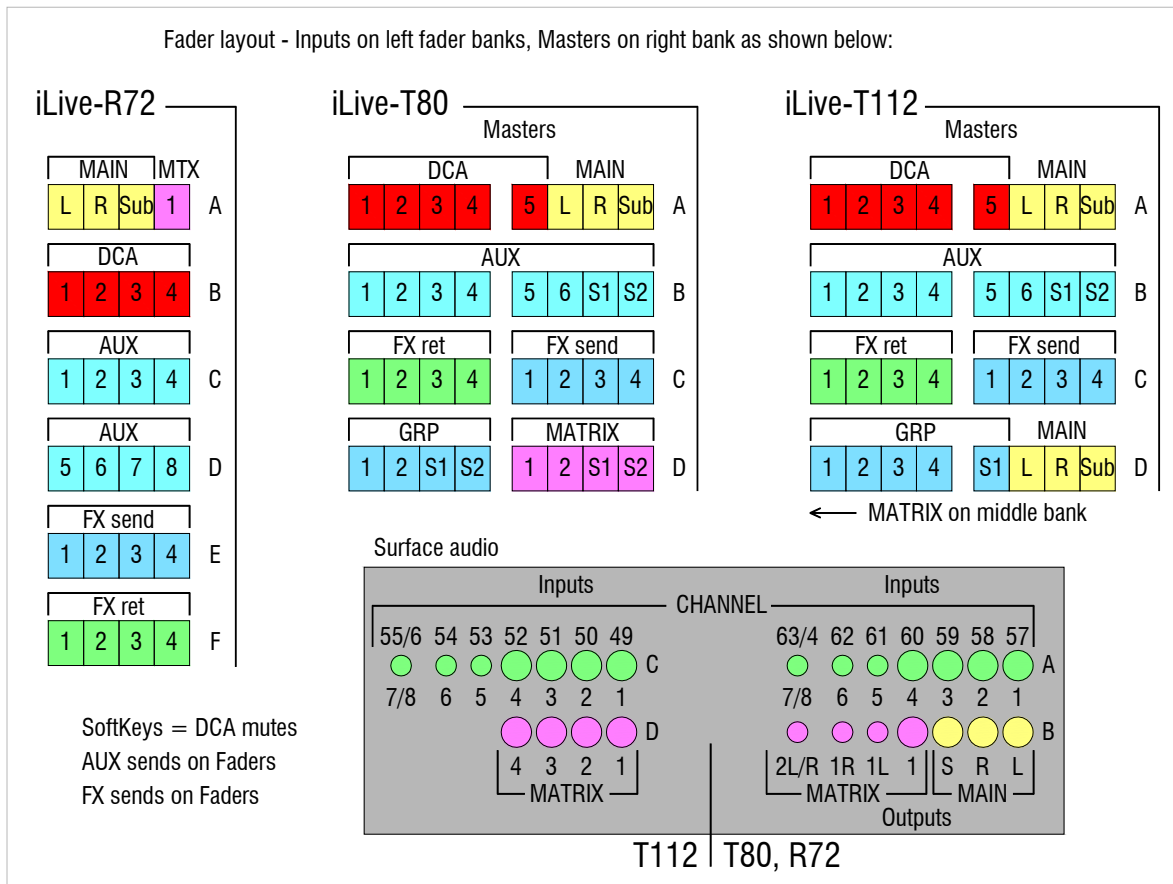

Fixed Format iLive - Template Show 4_MON-8m8st

Dedicated Monitor console

Assigned to surface: 6 Wedge, 2 Sidefill, 6 stereo IEM, 2 FX, engineer's listen Wedge/IEM

Bus configuration	2 mono, 1 stereo Groups	Channels	CH1 - 60 = mono
	8 mono, 6 stereo Auxes		CH61/62, 63/64 = stereo
	6 mono FX sends	FX	6 Send>Return stereo FX
	2 mono, 1 stereo Matrix		2 insertable stereo FX
	16 DCAs		

You can change the configuration and layout to suit your application
Name and archive your new configuration as a User Show

Fader layout - Inputs on left fader banks, Masters on right bank as shown below:

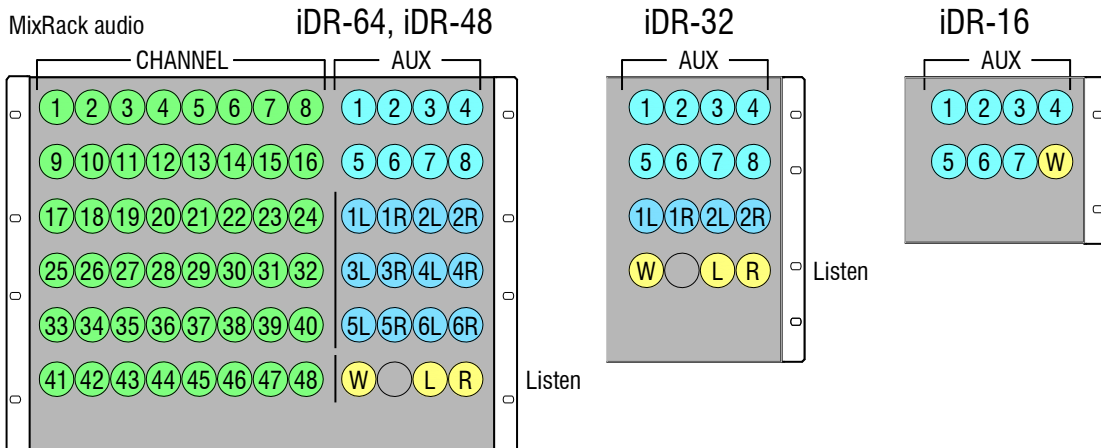
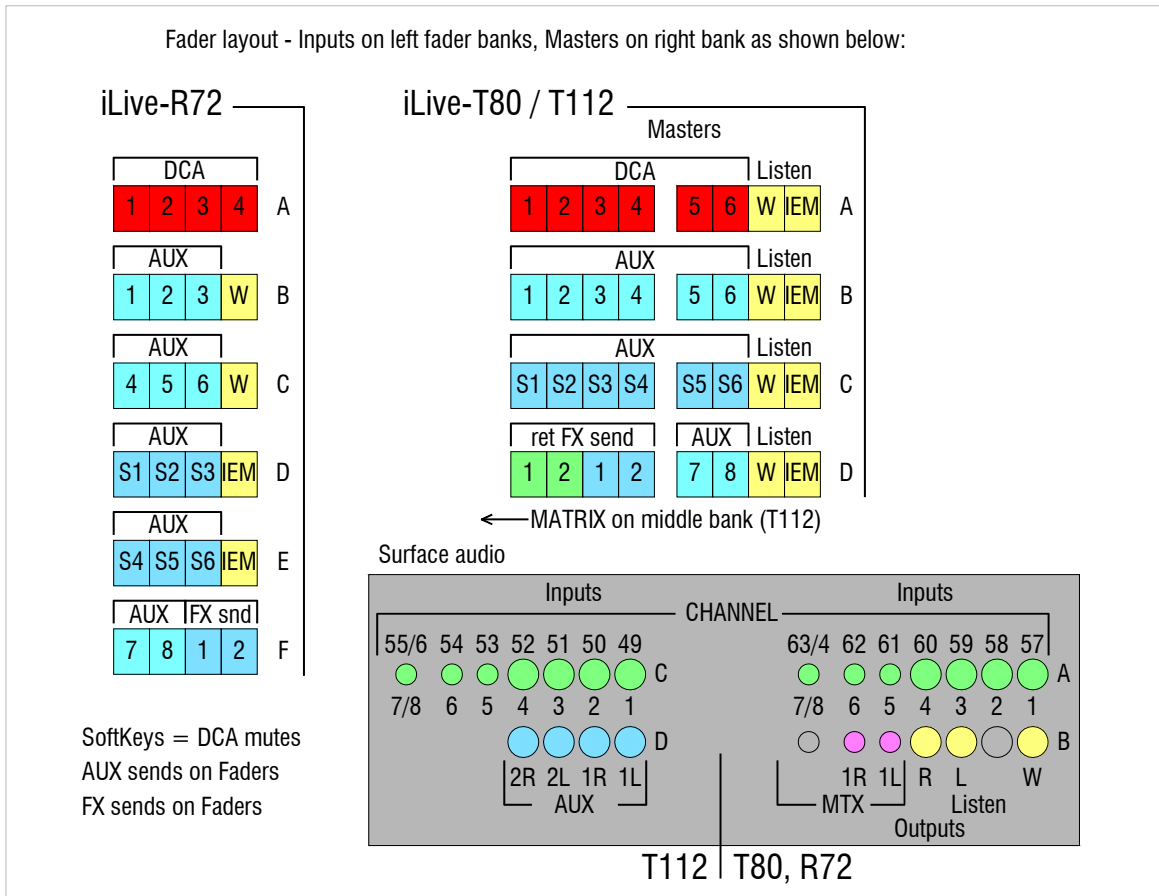

Inputs		Dimensions and Weights	
XLR Mic/Line Inputs	Balanced XLR, +48V phantom power	Modular iLive	Width x Depth x Height
Mic/Line Preamp	Fully recallable	iDR10 MixRack 9U	482 x 350 x 400mm (19" x 13.8" x 15.8") 26kg (57lbs)
Input Sensitivity	-65 to +15dBu	iDR0 MixRack 2U	482 x 310 x 88mm (19" x 12.2" x 3.5") 7.3kg (16lbs)
Analogue Gain	+10 to +65dB, 1dB steps	iLive-112 Surface	1006 x 707 x 353mm (39.6" x 27.7" x 13.9") 43kg (95lbs)
Pad	-25dB	iLive-144 Surface	1206 x 707 x 353mm (47.5" x 27.7" x 13.9") 48kg (106lbs)
Maximum Input Level	+32dBu	iLive-176 Surface	1406 x 707 x 353mm (55.4" x 27.7" x 13.9") 54kg (119lbs)
Input Impedance	>4kΩ (Pad out), >10kΩ (Pad in)	iPS10 Backup PSU 2U	482 x 310 x 88mm (19" x 12.2" x 3.5") 7kg (15lbs)
Mic EIN	-127dB with 150Ω source		
TRS Line Inputs	Balanced 1/4" TRS jack (T and R Series)	Fixed Format iLive	Width x Depth x Height
Input Sensitivity	Nominal +4dBu	iDR-16 MixRack 3U	482 x 300 x 132mm (19" x 11.8" x 5.2") 7.5kg (16.5lbs)
Trim	+/-24dB, recallable	iDR-32 MixRack 6U	482 x 250 x 265mm (19" x 10" x 10.4") 12kg (26.4lbs)
Maximum Input Level	+22dBu	iDR-48 MixRack 8U	482 x 250 x 353mm (19" x 10" x 13.9") 16kg (35.2lbs)
Input Impedance	>6kΩ	iDR-64 MixRack 9U	482 x 250 x 399mm (19" x 10" x 15.7") 17.5kg (38.5lbs)
RCA Line Inputs	Unbalanced RCA phono (T and R Series)	iLive-R72 - With Sidetrims	472 x 540 x 237mm (18.6" x 21.3" x 9.3") 12kg (26.5lbs)
Input Sensitivity	Nominal 0dBu	iLive-T80	770 x 635 x 280mm (30.2" x 11" x 9.3") 20kg (44lbs)
Trim	+/-24dB, recallable	iLive-T112	1083 x 635 x 280mm (42.6" x 11" x 9.3") 27kg (59.4lbs)
Maximum Input Level	+18dBu	xDR-16 Expander Rack 3U	482 x 300 x 132mm (19" x 11.8" x 5.2") 7kg (15.4lbs)
Input Impedance	>10kΩ		
Digital Inputs	SRC on each pair. Up to 96kHz sampling rate	Control	
SPDIF	2 Ch RCA, 600mV, coax terminated input 75Ω	Faders	100mm motorised, up to 44 faders
AES (modular)	2 Ch XLR, 2.5Vpp balanced terminated 110 Ω	Fader Banks	Independent banks with 4 layers each
Optical (modular)	2 Ch Toslink	Control Strips	From 72 to 176 depending on Surface size
Digital Audio Clock In	BNC (modular iLive)	Touch Screen	8.4" TFT, 800x600 resolution
Outputs		Strip Display	LCD per strip, 7 assignable backlight colours
XLR Outputs	Balanced, Relay protected	SoftKeys	8 assignable keys
Output Impedance	<75Ω	Control Network	TCP/IP Ethernet, built-in 3-port switch
Nominal Output	+4dBu = 0dB meter reading	MIDI	Available at MixRack and Surface
Maximum Output Level	+22dBu	PL-Anet	At MixRack and Surface (modular), MixRack only (Fixed)
Residual Output Noise	-93dBu (muted, 20-20kHz)	Ganging	Up to 8 gangs with up to 8 channels each
TRS Line Outputs	Balanced, Relay protected (T and R Series)	DCA Groups	16 configurable as DCA or Mute Groups
Output Impedance	<75Ω	Processing	
Nominal Output	+4dBu = 0dB meter reading	Inputs	HPF, Gate, PEQ, Compressor, Lim/De-Esser, Delay
Maximum Output Level	+22dBu	Mixes	PEQ, GEQ, Compressor, Limiter, Delay
Residual Output Noise	-93dBu (muted, 20-20kHz)	Internal FX	8x RackFX engine
RCA Line Outputs	Unbalanced, Relay protected	Types	Reverbs, Delays, Modulators, Sub-harmonics, Speaker Mtx
Output Impedance	<75Ω	Mode	Dynamic-EQ, Multiband Compressor
Nominal Output	0dBu = 0dB meter reading	FX 'Short' Return Channels	
Maximum Output Level	+18dBu	8 Stereo dedicated returns	Adds to inputs for up to 72 sources to the mix
Residual Output Noise	-95dBu (muted, 20-20kHz)	FX Return PEQ	Same as Input Channel PEQ
Digital Outputs	48kHz sampling rate	Dynamic FX	DFX ducking and gating shaper
SPDIF	2 Ch RCA, 600mV, coax terminated input 75Ω	Talkback	Assignable source
AES (option)	2 Ch XLR, 2.5Vpp balanced terminated 110 Ω	High Pass Filter	12dB/octave, 20Hz-400Hz
Optical (modular)	2 Ch Toslink	Routing	To Groups, Aux, Main, Matrix
Digital Audio Clock Out	BNC (modular iLive, MADI)	Signal Generator	Sine, White Noise, Pink Noise, Bandpass Noise
System		Sine, Bandpass sweep	20-20kHz
Measured balanced XLR in to XLR out, 20-20kHz, minimum Gain, Pad out		Controls	Level, Mute
Dynamic Range	112dB	Routing	To Groups, Aux, Main, Matrix
System Signal to Noise	-90dB	RTA	
Frequency Response	20Hz - 20kHz +0/-0.5dB	Source	31-Bands 1/3 octave 20-20kHz
THD+N (analogue in to out)	0.0015% @ +16dBu output, 1kHz 0dB gain	Peak Band Indication	Follows selected PAFL source
Headroom	+18dB		Option to display dominant frequency
Internal operating Level	0dBu	Memories	
dBFS Alignment	+18dBu = 0dBFS (+22dBu at XLR output)	Libraries	For processing, FX, whole channel. USB transfer
Meter Calibration	0dB meter = -18dBFS (+4dBu at XLR out)	Scenes	250 - Store all or selected parameters, Recall Safes
Meter Peak indication	-3dBFS (+19dBu at XLR out)	Shows	Archive all settings, Scenes Libraries. USB transfer
Meter Type	Fast (peak) response	User Profiles	8 - Admin and 7 users - Passwords, permissions
Sampling Rate	48kHz +/-100PPM		
ADC	24-bit Delta-Sigma	iLive Concept	
DAC	24-bit Delta-Sigma	MixRack	The rack is the DSP mixer. Can be used without the Surface
Latency	<2ms (MixRack XLR in to XLR out)	Surface	The Surface is a controller with remote audio I/O
Operating Temperature Range	ACE link is 100us (0.1ms) per hop 0 deg C to 35 deg C (32 deg F to 95 deg F)	Digital Snake (modular)	Single CAT5 ACE™ link, ES, Dante or MADI option
Mains Power		Digital Snake (fixed format)	Single CAT5 ACE™ link
Modular iLive	100-240V AC, 47-63Hz, 320W max	Port B digital I/O option	64 channel bi-directional audio
Fixed format iLive	100-240V AC, 47-63Hz, 160W max	System Expansion	Dual-Rack linking for 128 input channels

FIXED FORMAT iLIVE SURFACE

iLIVE-T112

T112 WEIGHT = 27kg / 59.4lbs

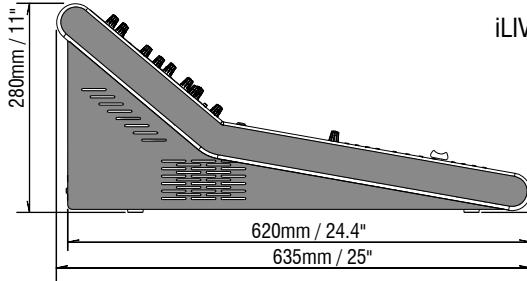
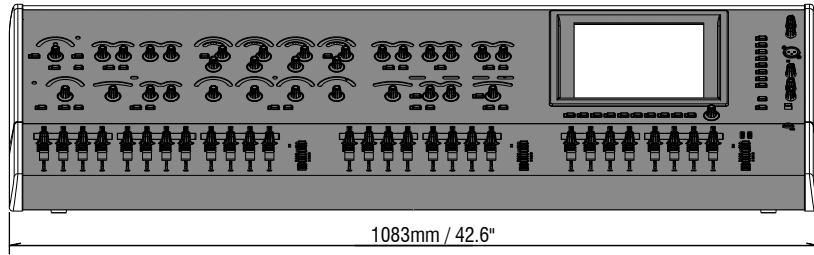

iLIVE-T80

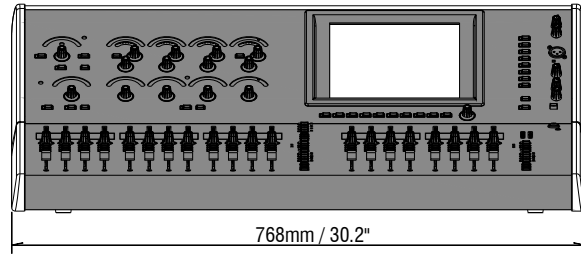

46mm / 1.8\"/>

RACKS

- iDR-16 MixRack WEIGHT = 7.5kg / 16.5lbs
- iDR-32 MixRack WEIGHT = 12kg / 26.4lbs
- iDR-48 MixRack WEIGHT = 16kg / 35.2lbs
- iDR-64 MixRack WEIGHT = 17.5kg / 38.5lbs
- xDR-16 Expander WEIGHT = 7kg / 15.4lbs

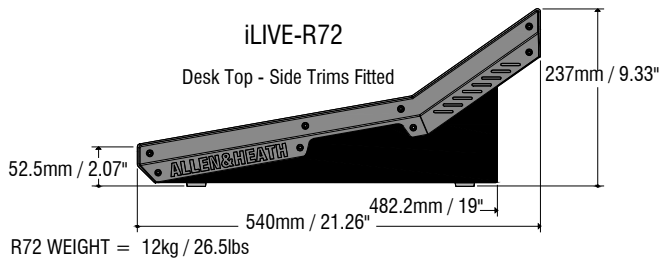
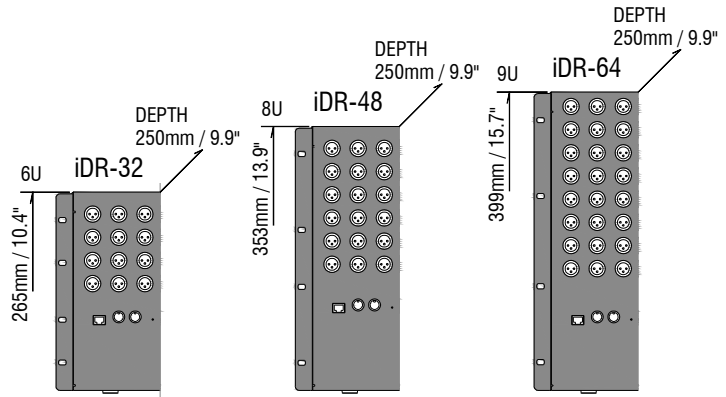
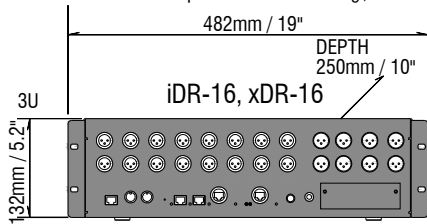

R72 WEIGHT = 12kg / 26.5lbs

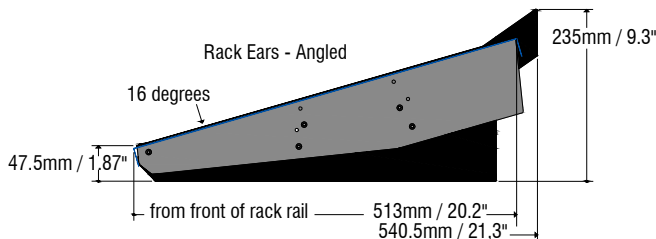
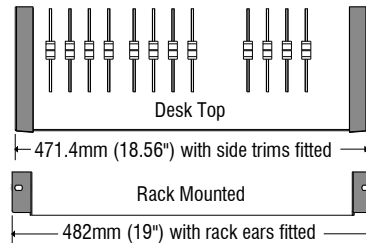
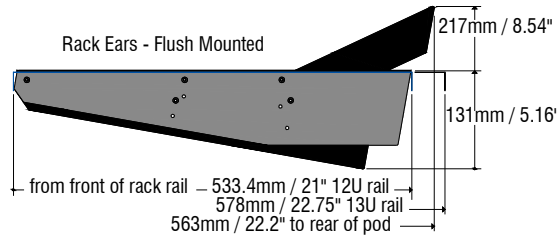

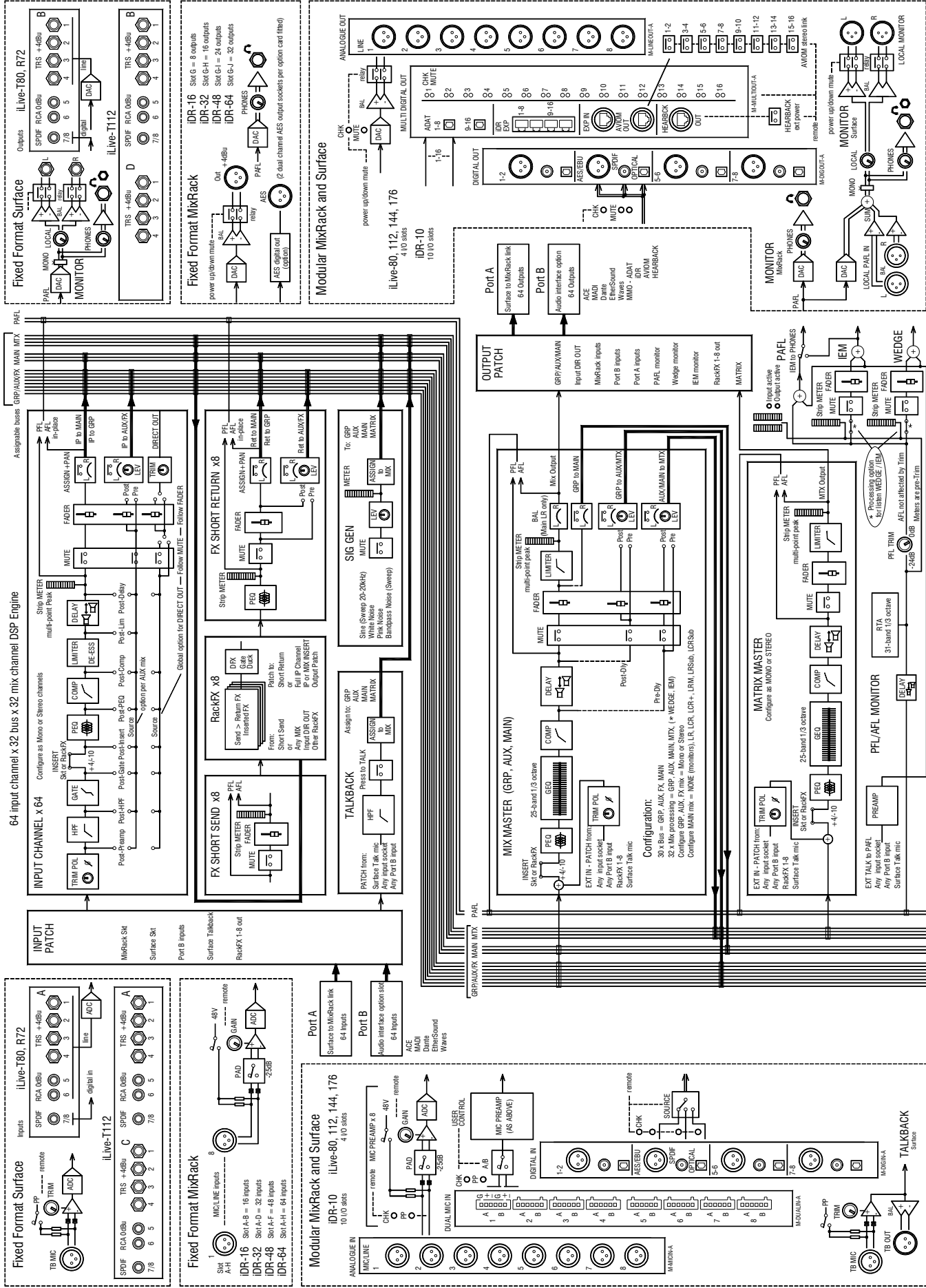

Limited One Year Manufacturer's Warranty

This product is warranted to be free from defects in materials or workmanship for period of one year from the date of purchase by the original owner.

To ensure a high level of performance and reliability for which this equipment has been designed and manufactured, read this User Guide before operating.

In the event of a failure, notify and return the defective unit to the place of purchase. If this is not possible then please contact the authorised ALLEN & HEATH distributor or agent in your country as soon as possible for repair under warranty subject to the following conditions.

Conditions Of Warranty

The equipment has been installed and operated in accordance with the instructions in this User Guide.

The equipment has not been subject to misuse either intended or accidental, neglect, or alteration other than as described in the User Guide or Service Manual, or approved by ALLEN & HEATH.

Any necessary adjustment, alteration or repair has been carried out by an authorised ALLEN & HEATH distributor or agent.

This warranty does not cover fader wear and tear.

The defective unit is to be returned carriage prepaid to the place of purchase, an authorised ALLEN & HEATH distributor or agent with proof of purchase. Please discuss this with the distributor or the agent before shipping.

If the unit is to be repaired in a different country to that of its purchase the repair may take longer than normal, whilst the warranty is confirmed and parts are sourced.

Units returned should be packed to avoid transit damage.

In certain territories the terms may vary. Check with your ALLEN & HEATH distributor or agent for any additional warranty which may apply.

If further assistance is required please contact Allen & Heath Ltd.

